

REDGUM LITTLE AUSSIE LOG SPLITTER

Owner's Manual

Operating Instructions for
RedGum Little Aussie Model

POWERED by
HONDA™



REDGUM SPLITTERS

Australia's No.1 Selling Honda Powered Log Splitters

Product Description & Intended Purpose:

This Log Splitter / Wood Splitter is an outdoor product that splits wood logs for use as fuel in a fireplace or a woodstove.



WARNING: All operators must read this manual, before operating this RedGum Splitter.

WARNING

Read and thoroughly understand all instructions contained in this operations manual before operating the RedGum Splitter.

Serious injury or death can result if safety instructions are not understood or followed. If you wish to discuss this log splitter's operational procedures after reading this manual, please call our customer service personnel on 1300 039 251. Monday - Friday

Hazard Signals Definition



This is the **safety alert symbol**. It is used to alert you to potential personal injury hazards. Obey all safety messages that follow this symbol to avoid possible injury or death.

DANGER

DANGER indicates an imminently hazardous situation which, if not avoided, will result in serious injury or death.

WARNING

WARNING indicates a potentially hazardous situation which, if not avoided, will result in serious injury or death.

CAUTION

CAUTION indicates a potentially hazardous situation which, if not avoided, could result in minor or moderate injury.

Table of Contents

| | |
|---|-----|
| Important Safety Rules..... | 4-5 |
| Operation Instructions | 7 |
| Proper Operation of the Log Splitter | 7 |
| How to split a log with slanted surface | 8 |
| Horizontal & Vertical Operating Modes | 9 |
| Vehicle Towing of the Log Splitter | 10 |
| Log Splitter Components | 11 |
| Log Splitter Troubleshooting | 12 |
| Maintenance and Storage | 13 |
| Engine Components & Specifications..... | 14 |
| Notes | 15 |
| Accessories | 16 |



Important Safety Rules



WARNING



1.) Read this manual completely.

- Serious injury or death can result if safety instructions are not followed.
- Everyone who operates this log splitter must read and completely understand all safety rules, operating instructions, and maintenance instructions.
- You must be 18 or older to operate this machine and in sound mind, free of the influence of medication, drugs or alcohol. Keep untrained people away.



2.) Crush hazard.

The Crush Hazard Zone is between the splitter wedge(5) and the end plate(18). Wedge(5) can cut through skin and break bones. Make sure hands are clear of crush hazard zone when log splitter is in operation.



3.) Flying objects.

- Pieces of log may fly out while splitting. Wear safety glasses. Serious eye injury can occur if safety glasses are not worn.
- Serious accidents can happen when other people are allowed inside the safety and operator zone. Keep everyone else out of the safety and operator zone while operating log splitter. See page 7 for operator zone.



4.) Skin injection hazard.

- High pressure fluid can inject under skin resulting in serious injury including amputation.
- If skin injection happens, seek immediate "Surgical Treatment". Call 000
- Make sure all fittings are tight before starting the log splitter. Relieve system pressure before servicing by turning off the log splitter and moving control valve lever(4a) forward and back and returning to neutral position.
- Do not check for leaks with hand. Instead, use a piece of cardboard to check for leaks.



Important Safety Rules (continued)

WARNING



6.) Risk of fire and explosion.

Hot exhaust fumes from engine can cause fire. Gasoline is highly flammable and explosive. You can be burned or seriously injured when handling fuel.

- Position muffler at least 7 feet from combustible objects.
- Before adding fuel, stop the engine and keep heat, sparks, and flame away. Do not add fuel when engine is running or still hot. No smoking near engine.
- Do not pump fuel directly into engine at gas station. Static charge can build and ignite fuel. Use an approved fuel container to transfer petrol to the engine. Wipe up fuel spills immediately.
- Store and handle fuel outdoors. Gasoline vapors can ignite if they collect inside an enclosure. Explosion can result.
- Do not change or add to exhaust system. Fire can result.
- Do not change or add fuel tanks or fuel lines. Fire can result.
- Before each use, check fuel tank and fuel lines for leaks. Any fuel leak is a fire hazard. Fix any fuel leaks before starting engine.
- During transportation take precautions to make sure machine will not tip over and cause a fuel leak and fire hazard. Engine fuel lever should be turned to off while transferring this log splitter.



7.) Breathing hazard.

Poisonous fumes from engine can kill you. Do not operate indoors even if ventilated. This product is for outdoor use only.



8.) Hot muffler.

You can be burned by muffler. Do not touch muffler during or immediately after use.

WARNING

Read & thoroughly understand the following Operational Warnings before operating this RedGum Log Splitter.

Operational Warning

- **Intended purpose:** This product is designed as an outdoor product to split wood logs to use as fuel in a fireplace or a woodstove. Never use the log splitter for any other purpose than splitting wood.
- **Always place logs so the axehead splits with the wood grain and not across the wood grain.**
- **Personal Protective Equipment:** Safety glasses are required to be worn at all times. It's also recommended to wear 1. Ear Muffs 2. Steel capped boots 3. Tight fitting gloves.
- **ALWAYS wear suitable clothing, free from hanging strings, jewellery or other items that could get caught up in moving parts. If you have long hair make sure it is tied back and kept out of the way of moving parts.**
- **ALWAYS inspect log splitter before using to ensure it is in good working condition.**
- **Replace or repair damaged or worn parts immediately.**
- **ALWAYS check and tighten hardware and assembled parts before operation.**
- **ALWAYS operate log splitter on firm, clear and level ground**
- **ALWAYS set up a SAFETY ZONE restricting onlookers to at least 3m away from the log splitter when in use.**
- **ALWAYS remove split wood from around the log splitter immediately after it's spilt into smaller pieces so that you don't stumble over it.**
- **Do NOT exceed equipment maximum splitting capacity by altering component settings.**
- **Do NOT operate the log splitter at night, only during daylight hours.**
- **Shut engine off before leaving log splitter unattended.**

Keep this operations manual for future reference and re-read this manual periodically.

Operation Checklist

RedGumSplitters are assembled and ready for use however,

- **Check** Hydraulic Oil levels with a Dipstick
- **Check** engine oil level by sighting engine dip stick.
- Closely **inspect** all log splitter components. If you sight damaged components then contact your RedGum dealer before use.
- **Always wear safety glasses** while operating this logsplitter. It's also recommended to wear 1. Ear Muffs 2. Steel capped boots 3. Tight fitting gloves 4. Suitable clothing

OPERATION INSTRUCTIONS

Proper Operation of the Log Splitter.

- 1.) Always follow Operational warnings & checklist(refer page 6).
- 2.) Load a log onto the beam (7) and against the end plate (18). (See next page for instructions on splitting logs with a slant or uneven surfaces) However log should be cut as square as possible to fit properly on to the splitter and firmly against the end plate (18).
- 3.) Serious accidents can happen when other people are allowed inside the OPERATOR ZONE (see diagram below). Keep everyone out of the operator zone while operating the log splitter.
b.) ALWAYS set up a SAFETY ZONE restricting onlookers to at least 3m away from the log splitter when in use.

4.) Start Engine by using the following instructions:

- a. Turn the engine switch to 'ON' position.
- b. Slide the choke lever away from the fuel tank to activate the choke.
- c. Turn the fuel tap on.
- d. Raise the engine revs by sliding the throttle lever away from the fuel tank. Always use full throttle when using this machine.
- e. Pull the starter cord handle lightly until resistance is felt, then pull briskly.
- f. When the engine starts to run, deactivate the choke by sliding the lever towards the fuel tank.
- g. CAUTION Do not let go of the starter cord and allow it to snap back.

5.) Start the splitting procedure by pushing and holding the control valve handle (4) FORWARD.

⚠ WARNING The Crush Hazard Zone is between the splitter wedge(5) and the end plate(18). Make sure hands are clear of crush hazard zone.

- a. To return wedge to starting position simply pull the control valve lever (4a) backwards and away from the end plate (18). Please note that the splitter wedge(5) only moves forward when you are holding the lever forward. When you let go of the control lever(4a) the splitting wedge should stop.
- b. Please note the splitting wedge returns back to the original starting position automatically. You must ensure control lever(4a) returns to the neutral position after the splitting wedge has returned to it's original starting position.
- c. For safety reasons, the wedge(5) stops approx. 3-4cm from the endplate(18). To avoid hydraulic pressure build up please refrain from holding the control lever (4a) forward after the wedge has reached the end of it's travel.

7.) Clear the split wood from the operator zone.

8.) Repeat above steps as required.

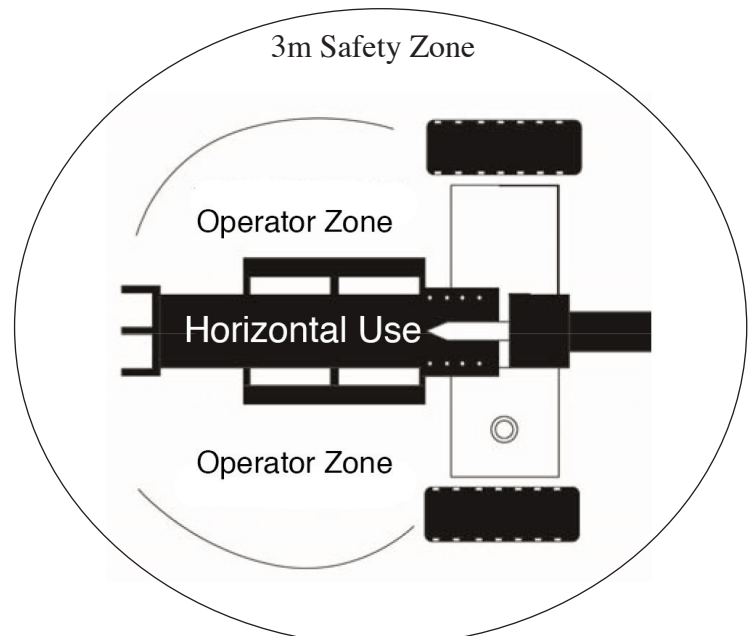
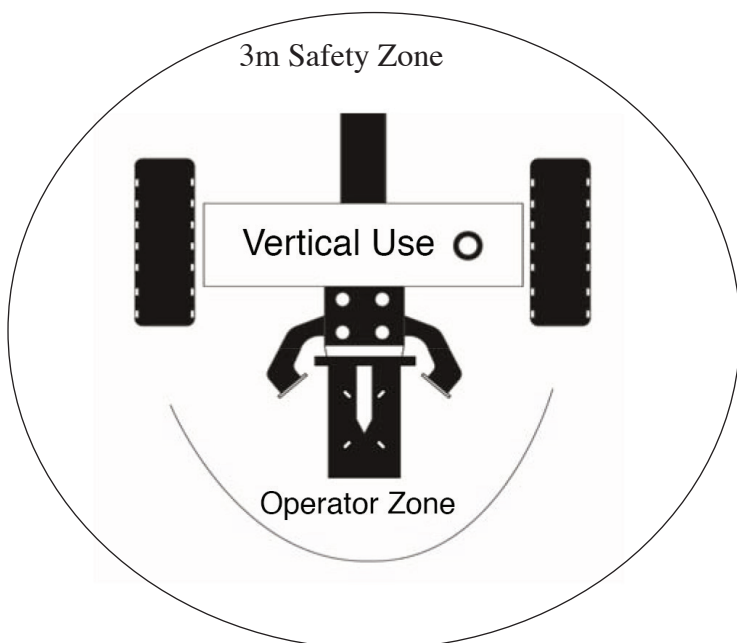

OPERATION INSTRUCTIONS (continued 2)

How to split a log with slant(or uneven) surface

Correct operating procedures are required to ensure your RedGum logsplitter is not damaged. Incorrect operation can result in bending the beam(7) and/or end plate(18). Important: If beam or end plate are bent due to incorrect operation, it is not a manufacturers fault and subsequently is not covered under warranty.

Ideally the log should be cut into “rounds” with flat or even surfaces. If they are cut and the edges are on an angle or have an uneven surface, you must ensure you place the log onto the beam(7) as shown in the diagrams BETTER or BEST below.

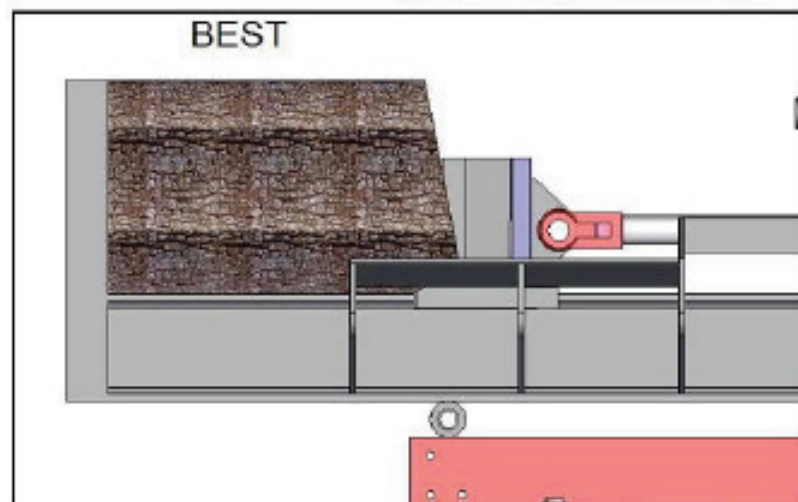
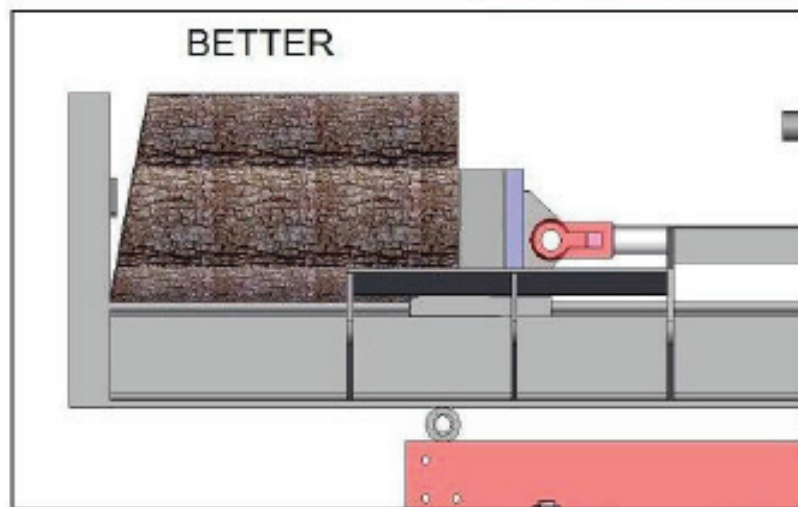
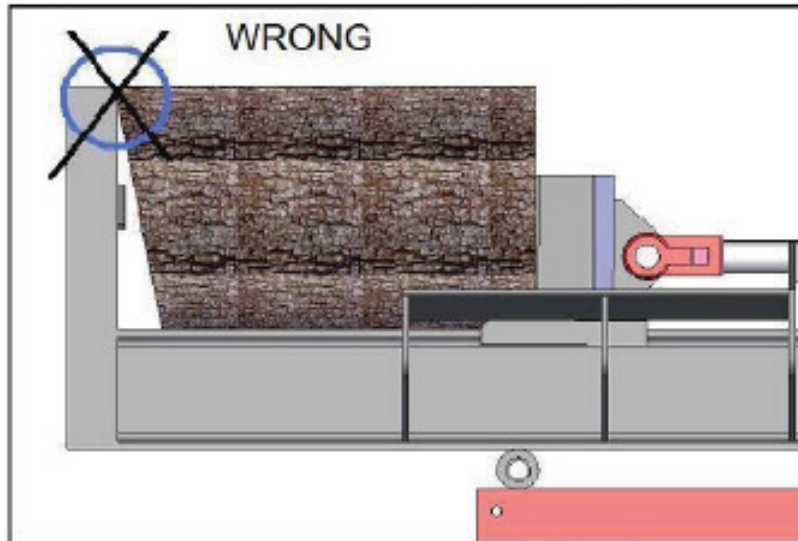

OPERATION INSTRUCTIONS (continued 3)

For Horizontal Use:

WARNING

Important: Note position of "locking pin tab". This is required for vertical operation.

Rotate rear leg down and slide the lock pin into top hole to lock rear leg into place.

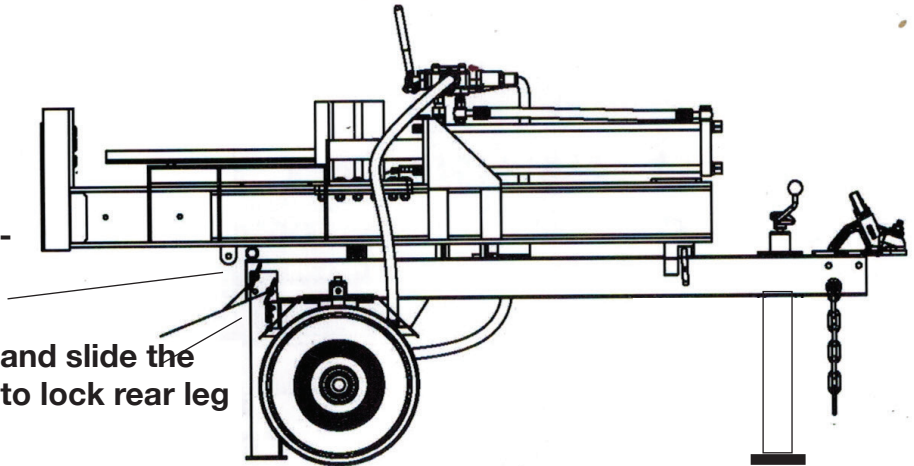

CAUTION

When converting the log splitter from horizontal to vertical use and/or returning to horizontal from vertical operation, the rear leg must be secured in downward with locking pin to prevent the tow bar from snapping up.

Image shows rear leg lock down

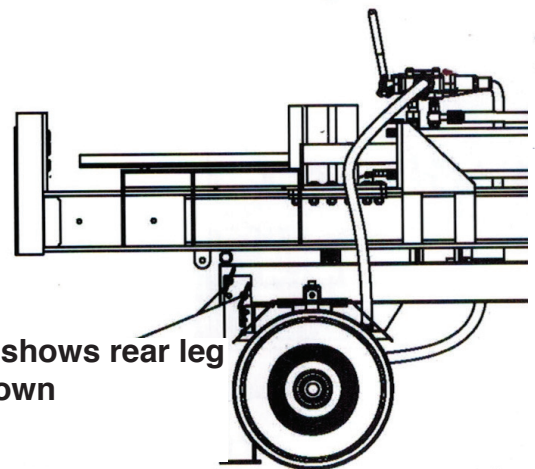

For Vertical Use:

WARNING

Remove the work table before operating in vertical mode.

Beam end handle

- Step 1: Ensure rear leg is down
- Step 2: Pull out pin
- Step 3: Lift beam to vertical
- Step 4: Insert locking pin

WARNING

To secure beam in vertical position you **MUST** place the pin through the top hole of the rear leg **AND** through the "locking pin tabs" on the back of splitting beam as shown on horizontal use diagram.

Beam Lock Pin

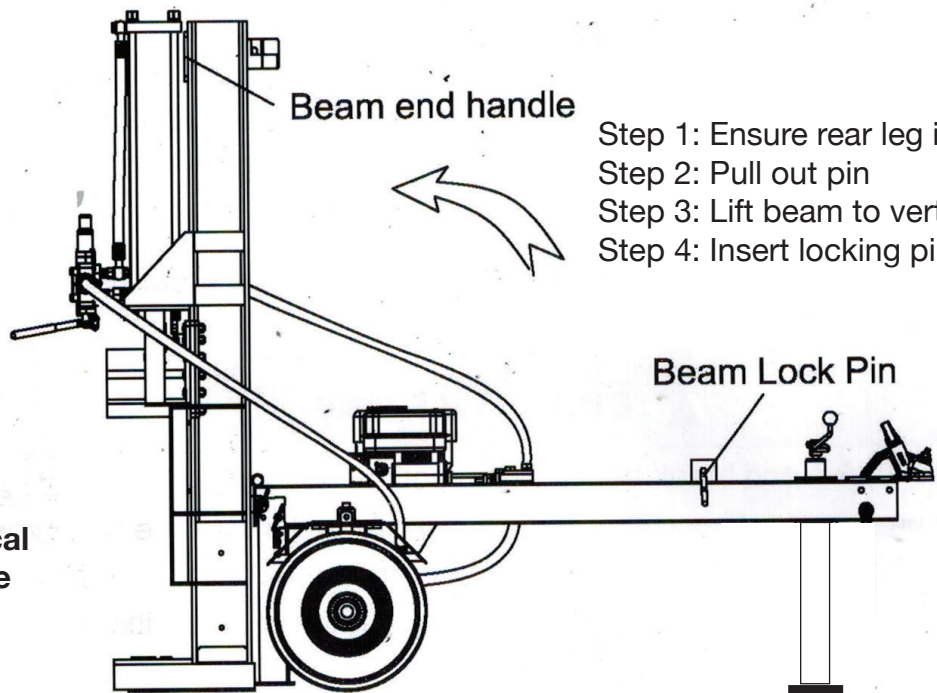

Towing the log splitter:

1a.) Ensure log splitter is secured in horizontal mode. (See 1b & 1c)

2.) Ensure log splitter tow hitch is locked onto vehicle tow ball.

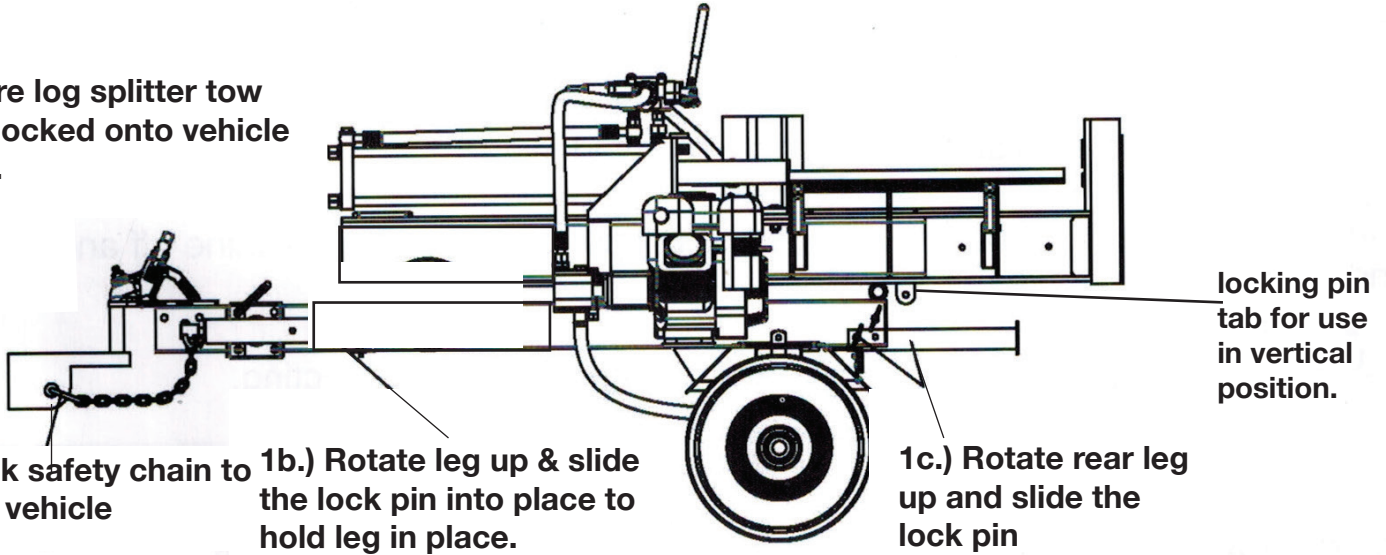

Remember to turn the engine fuel tap off prior to towing to prevent flooding of the engine.



WARNING

Towing incorrectly is a serious risk and can result in serious injury or death. Please read Towing Warnings below:



WARNING

Towing Warnings:

Remember to turn the engine to the off position prior to towing and turn off fuel tap.

- Serious injury or death can occur if towing safety rules are not followed.
- Review towing safety warnings in your towing vehicle manual.
- Drive safely. Be aware of the added length of the log splitter adds to your vehicle.
- Never ride or transport cargo on the log splitter.
- ALWAYS secure and lock the log splitter to the vehicle hitch before towing.
- Drive the vehicle only after the log splitter is securely attached.
- Turn off the vehicle before leaving the log splitter unattended.
- Choose a level surface to operate the log splitter.
- Block the log splitter wheels to prevent unintended movement.
- Never tow or operate this splitter while under the influence of alcohol, drugs, or medication. AVOID large holes and ditches when towing the equipment.
- ALWAYS tow at reduced speed on rough or uneven terrain, along creeks, ditches and on hillsides.
- To AVOID personal injury and/or equipment damage DO NOT EXCEED 45 km/h.

LOG SPLITTER COMPONENTS

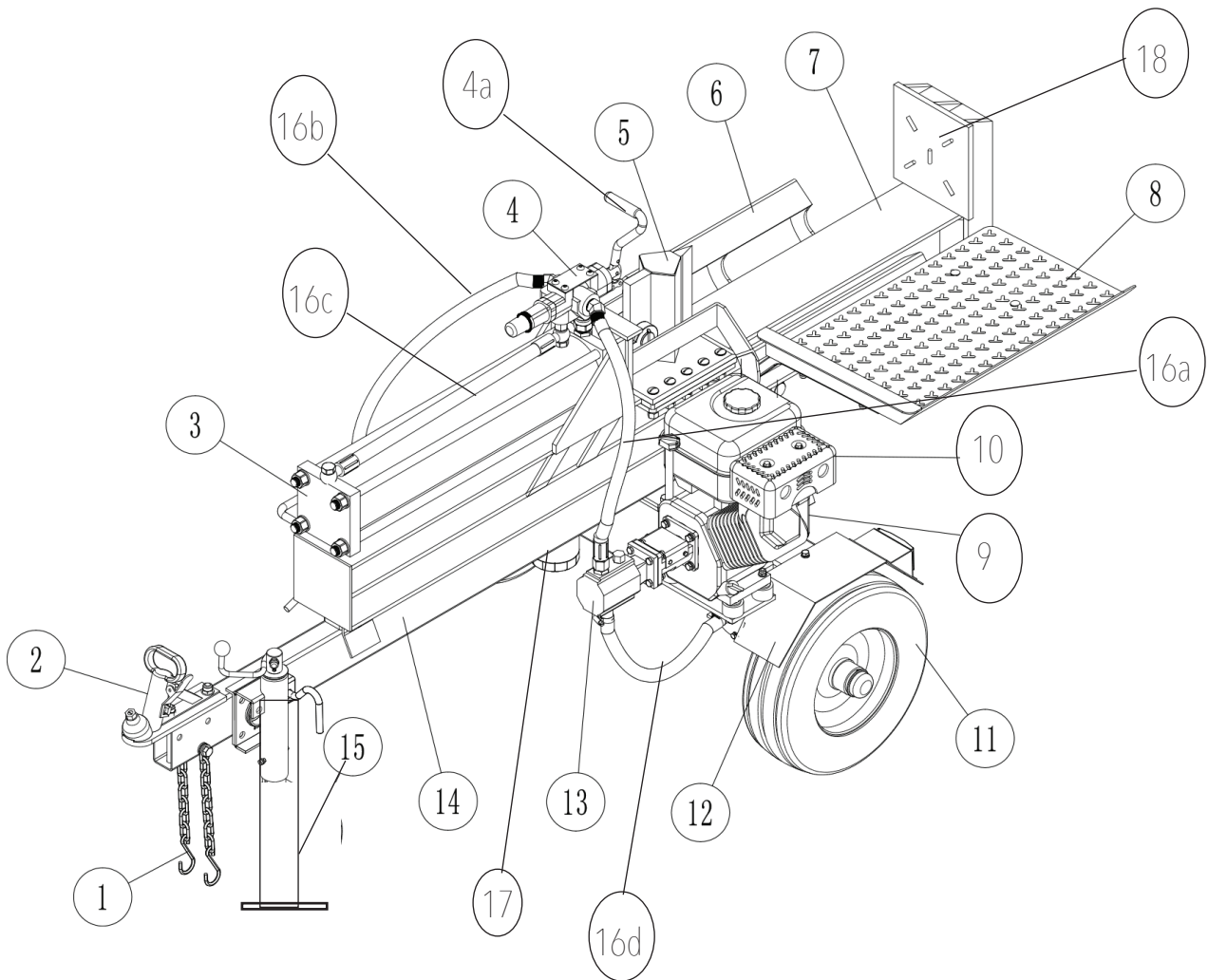

- 1.) Safety Chains. A safety feature to prevent loss of log splitter while towing.
- 2.) 50mm Trailer Coupler. Attaches to your vehicle. Fits standard 50mm hitch balls.
- 3.) Hydraulic Cylinder. The Hydraulic cylinder has a 4 ½” bore, 22¾” stroke.
- 4.) Control Valve. 4a.) Control Valve Handle. Use the control valve handle to move the Splitter wedge slide forward and backward.
- 5.) Splitter Wedge. The splitter wedge features wings and a taper that makes splitting easier.
- 6.) Log Cradle. Keeps the log on the beam without operator assistance.
- 7.) Beam. The beam is made of 6” wide flange beam (also called I-Beam) and is reinforced.
- 8.) Work Table. Maximum load 20Kg.
- 9.) Engine. The air cooled Honda GX200 engine powers the hydraulic pump.
- 10.) Rear Support Leg.
- 11.) Wheel/Tyre. Maximum rated speed is 45 km per hour.
- 12.) Fender.
- 13.) Two Stage Hydraulic Pump. Makes the hydraulic oil flow through the system.
- 14.) Tow Bar.
- 15.) Front support leg
- 16.) Hydraulic Hoses. a.) Inlet Hose, b) Outlet Hose, c) Cylinder Hose, d) Oil pipe
- 17.) Hydraulic Oil filter to increase the service life of the log Splitter components.(if applicable)
- 18.) End Plate

LOG SPLITTER TROUBLESHOOTING

| Problem | |
|--|-------------------------------|
| Cylinder rod & splitting wedge will not move | Solution: A, D, E, H, J |
| Slow cylinder shaft speed when extending or retracting | Solution: A, B, C, H, I, K, L |
| Wood will not split or splits extremely slowly | Solution: A, B, C, F, I, K |
| Engine bogs down during splitting | Solution: G, L |
| Engine stalls under low load condition | Solution: D, E, L, M |

| Cause | Solution |
|--|---|
| A - Insufficient oil to pump | Check oil level in reservoir |
| B - Air in oil | Check oil level in reservoir |
| C - Excessive pump inlet vacuum | Check pump inlet hose for blockage or kinks |
| D - Blocked hydraulic lines | Flush & clean the splitter hydraulic system |
| E - Blocked control valve | Flush & clean the splitter hydraulic system |
| F - Low control valve setting | Adjust control valve with a pressure gauge |
| G - High control valve setting | Adjust control valve with a pressure gauge |
| H - Damaged control valve | Return control valve for authorised repair |
| I - Internal control valve leak | Return control valve for authorised repair |
| J - Internal cylinder leak | Return cylinder for authorised repair |
| K - Internally damaged cylinder | Return cylinder for authorised repair |
| L - Engine control out of adjustment | Return for authorised repair |
| M - Engine is loaded during idle down mode | Use shorter log length (24" or less) to allow engine to speed up before contact |

MAINTENANCE, STORAGE AND ESSENTIAL CHECKS BEFORE USE

Before performing maintenance, the log splitter must be placed in maintenance mode.

To do so follow these steps:

- 1.) Turn off engine
- 2.) Move the control valve handle (4a) forward and backward to relieve **Hydraulic Pressure**.

After performing maintenance, make sure all guards, shields and safety features are put back in place. Failure to follow this warning can result in serious injury.

Essential checks before each use

| What | When | How |
|--------------------|----------|--|
| Hoses | Each Use | Inspect for exposed wire mesh & leaks. Replace all worn or damaged hoses before starting engine. |
| Hydraulic Fittings | Each Use | Inspect for cracks & leaks. Replace all damaged fittings before starting engine. |
| Nuts & Bolts | Each Use | Check for loose bolts . Tighten before operating. |
| Beam | Each Use | Apply grease to beam surface |
| Moving Parts | Each Use | Clear debris |

Storage

- Before storing, make sure the log splitter is clean and dry for years of trouble-free service.
- Lightly lubricate all log splitter surface and moving parts to prevent rust.
- Store indoors or protected area during severe weather and winter months.
- It is essential to fully retract axe head, ensuring no silver part of piston rod is exposed to the elements.

Oil Filter:

After the first 25 hours of operation, change the oil filter. There after every 100 hours of use or seasonally change filter.

Refer to engine manual for engine maintenance.



WARNING

Skin injection hazard.

High pressure fluid can inject under skin resulting in serious injury including amputation.

- Make sure all hose and control fittings are tight before applying pressure.

Relieve system pressure before servicing.

- Do not check for leaks with hand. Instead, place a piece of cardboard under the unit to check for leaks.

- If skin injection happens, seek immediate 'Surgical Treatment'. Call 000.

ENGINE COMPONENTS

1. Fuel Cap
2. Fuel Tank
3. Oil Drain Plug
4. Oil Filler Cap/Dipstick
5. P.T.O Shaft
6. Muffler
7. Spark Plug
8. Choke Lever
9. Fuel Valve Lever
10. Starter Grip
11. Recoil Starter
12. Air Cleaner

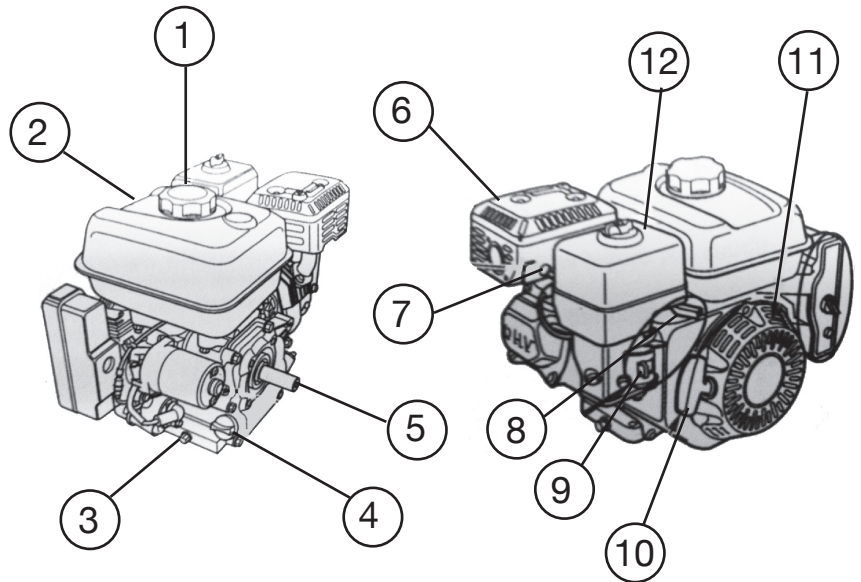

For more information on Engine Operation & Engine Maintenance please refer to engine manual supplied with the log splitter.

SPECIFICATIONS

| | |
|----------------------------------|------------------------|
| Tested Splitting Force | 30000kgs |
| Fastest Cycle Time | 20 Seconds |
| Solid Splitting Wedge Size | 20cm(8") |
| Hydraulic Tank Capacity..... | 14 Litres |
| Max. Log Length | 600mm (24") |
| Max. Log Weight..... | 45kgs (100Lbs) |
| Coupler Ball Size | 50mm |
| Tyre Size | 40mm (16") |
| Max. Towing Speed..... | 45 Km per hour |
| Cylinder Size | 4" x 23" |
| Max. Pressure | 3000 psi |
| Hydraulic Fluid Type | 10W-AW32 &/or 10W-AW46 |
| Gear Pump | 2 stage |
| Max. Flow Capacity..... | 46.8 LPM |
| Control Valve | Detent (auto-return) |

Overall Dimensions of the log splitter when horizontal

| | |
|--------------|-------------|
| Weight | 244Kg |
| Height | 1.2mm (45") |
| Width | 1.17 m |
| Length | 2.23 m |

Warranty Information

Please note down for future reference

RedGum Splitter Model: **Little Aussie**

Date of Purchase:

Serial Number:

Purchased from:

NOTES

The manufacturer reserves the right to make improvements in design and/or changes in specifications at any time without incurring any obligation to install them on units previously sold.

Accessories Available:

1.) RedGum Hydraulic Oil - Fluid 46 4L RRP \$40

Ideal for topping up log splitter's hydraulic reserve when required.



2.) RedGum Worktable RRP \$99

Improves productivity by preventing split logs from falling to the ground. Also reduces the effort of picking up split log that require further splitting.



3.) RedGum Log Splitter Cover RRP \$89

Extra Heavy Duty 200D cover that protects your log splitter from dust and rain.



4.) Log TurnTable RRP \$299

The Turn table accessory fits all RedGum Logsplitters, and allows for easy turning of heavy logs (for repeated splitting), when in the vertical splitting position.

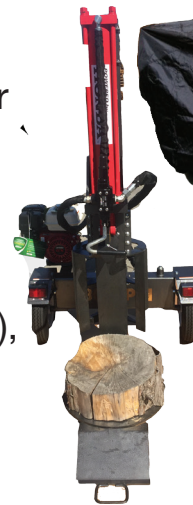

5.) Timber Jack Lifter RRP \$189

The timber jack lifts logs (up to 50cm in diameter), so you can cut the log without your chainsaw chain touching the dirt.



6.) Wood pick 40cm RRP \$89

Improves the speeds for which most forestry jobs can be carried out. Simply pierce the log with the wood pick to easily move the log from one place to another. Wood pick reduces the strain on the back by reducing the amount of bending involved during work. 60cm - \$100, 80cm - \$115

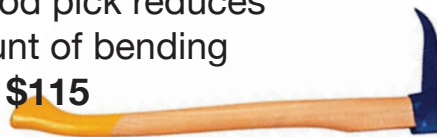

7.) Chainsaws

For chainsaws & chainsaw accessories, talk to your local RedGum Dealer

For more information contact your local RedGum Dealer Or visit www.RedGumProducts.com.au

Phone: 1300 039 251



Follow us on Facebook: www.facebook.com/redgumproducts