

RedGum 32000

Super HDV Lifter-Splitter



POWERED by
HONDA™

Owner's Manual

RedGum LOGSPLITTERS

Australia's No.1 Selling Honda-Powered Log Splitters

Product Description & Intended Purpose:

This Log Splitter / Wood Splitter is an outdoor product that splits wood logs for use as fuel in a fireplace or a woodstove.



WARNING: All operators must read this manual, before operating this RedGum Splitter.

WARNING

Read and thoroughly understand all instructions contained in this operation manual before operating this RedGum Splitter.

Serious injury or death can result if safety instructions are not understood or followed. If you wish to discuss this log splitter's operational procedures after reading this manual, please call our Customer Service on 1300 039 251, available Monday to Friday, from 9AM to 5PM AEDT.

HAZARD SIGNAL DEFINITIONS



This is the **safety alert symbol**. It is used to alert you to potential personal injury hazards. Obey all safety messages that follow this symbol to avoid possible injury or death.

DANGER

DANGER indicates an imminently hazardous situation which, if not avoided, will result in serious injury or death.

WARNING

WARNING indicates a potentially hazardous situation which, if not avoided, will result in serious injury or death.

CAUTION

CAUTION indicates a potentially hazardous situation which, if not avoided, could result in minor or moderate injury.

Table of Contents

Important Safety Rules	4-6
Check Prior to Operation	7
Operation Instructions	8
Towing the Log Splitter	9
Log Splitter Components	10
Log Splitter Specifications	11
Maintenance, Storage & Essential Checks	12
Risk Register	13
Log Splitter Troubleshooting	14
Warranty & Service Information	15-17
Accessories	18



Important Safety Rules



WARNING



1.) Read this manual completely.

- Serious injury or death can result if safety instructions are not followed.
- Everyone who operates this log splitter must read and completely understand all safety rules, operating instructions, and maintenance instructions.
- You must be 18 or older to operate this machine and in sound mind, free of the influence of medication, drugs or alcohol. Keep untrained people away.



2.) Crush hazard.

The Crush Hazard Zone is between the Splitting Wedge (8) and the Splitting Table (22). The Splitting Wedge (8) can cut through skin and break bones. Make sure hands are clear of crush hazard zone when log splitter is in operation.



3.) Flying objects.

- Pieces of wood may fly out while splitting. Wear safety glasses. Serious eye injury can occur if safety glasses are not worn.
- Serious accidents can happen when other people are allowed inside the safety and operator zone. Keep everyone else out of the safety and operator zone while operating log splitter. See page 7 for operator zone.



4.) Skin injection hazard.

- High pressure fluid can inject under skin resulting in serious injury including amputation.
- If skin injection happens, seek immediate "Surgical Treatment". Call 000
- Make sure all fittings are tight before starting the log splitter. Relieve system pressure before servicing by turning off the log splitter and moving Control Valve Lever (7) back to the neutral position.
- Do not check for leaks with hand. Instead, use a cloth or place a piece of card-board under the unit to check for leaks.

Safety Rules Continued...



Important Safety Rules

WARNING



5.) Risk of fire and explosion.

Hot exhaust fumes from the engine can cause a fire. Gasoline is highly flammable and explosive. You can be burned or seriously injured when handling fuel.

- Position muffler at least 7 feet from combustible objects.
- Before adding fuel, stop the engine and keep heat, sparks, and flame away. Do not add fuel when engine is running or still hot. No smoking near engine.
- Do not pump fuel directly into engine at gas station. Static charge can build and ignite fuel. Use an approved fuel container to transfer petrol to the engine. Wipe up fuel spills immediately.
- Store and handle fuel outdoors. Gasoline vapors can ignite if they collect inside an enclosure. Explosion can result.
- Do not change or add to exhaust system. Fire can result.
- Do not change or add fuel tanks or fuel lines. Fire can result.
- Before each use, check fuel tank and fuel lines for leaks. Any fuel leak is a fire hazard. Fix any fuel leaks before starting engine.
- During transportation take precautions to make sure machine will not tip over and cause a fuel leak and fire hazard. Engine fuel lever should be turned to off while transporting this log splitter.

6.) Breathing hazard.

Poisonous fumes from the engine can kill you. Do not operate indoors even if ventilated. This product is intended for outdoor use only.

7.) Hot muffler.

You can be burned by the muffler. Do not touch muffler during or immediately after use.

WARNING

Read & thoroughly understand the following Operational Warnings before operating this RedGum Log Splitter.

OPERATIONAL WARNINGS

- **Intended purpose:** This product is designed as an outdoor product to split wood logs to use as fuel in a fireplace or a woodstove. Never use the log splitter for any other purpose than splitting wood.
- **Always place logs so the axehead/Splitting wedge splits with the wood grain and not across the wood grain.**
- **ALWAYS inspect log splitter before using to ensure it is in good working condition.**
- **Replace or repair damaged or worn parts immediately.**
- **ALWAYS check and tighten fasteners, hardware and assembled parts before operation.**
- **ALWAYS operate log splitter on firm, clear and level ground**
- **ALWAYS set up a SAFETY ZONE restricting onlookers to at least 3m away from the log splitter when in use.**
- **ALWAYS remove split wood from around the log splitter immediately after it's spilt into smaller pieces so that you don't stumble over it.**
- **Do NOT exceed equipment maximum splitting capacity by altering component settings.**
- **Do NOT operate the log splitter at night, only during daylight hours.**
- **Shut engine off before leaving log splitter unattended.**

RedGum Splitters are assembled and ready for use however:

- **Check** Hydraulic Oil levels with a Dipstick
- **Check** engine oil level by sighting engine dip stick.
- **Closely inspect** all log splitter components. If you sight damaged components then contact your RedGum dealer before use.
- **Always wear safety glasses** while operating this log splitter. It's also recommended to wear Ear Muffs, Steel capped boots, Tight fitting gloves and Suitable clothing - A free from hanging strings, jewelery or other items that could get caught up in moving parts. If you have long hair make sure it is tied back and kept out of the way of moving parts.

Keep this operations manual handy for future reference and re-read this Owner's Manual periodically.

PRE-OPERATION CHECKS

Essential checks to be carried out before each use:

What	When	How
Hoses	Each Use	Inspect for exposed wire mesh & leaks. Replace all worn/damaged hoses before starting engine.
Hydraulic Fittings	Each Use	Inspect for cracks & leaks. Replace all damaged fittings before starting the engine.
Nuts & Bolts	Each Use	Check for loose bolts. Tighten before operating.
Beam	Each Use	Apply grease to beam surface (if required).
Moving Parts	Each Use	Clear debris

Serious accidents can happen when other people are allowed inside the **OPERATOR ZONE** (see following diagram). Keep everyone out of the operator zone while operating the log splitter. **ALWAYS set up a SAFETY ZONE** restricting onlookers to at least 3 meters away from the log splitter when in use.

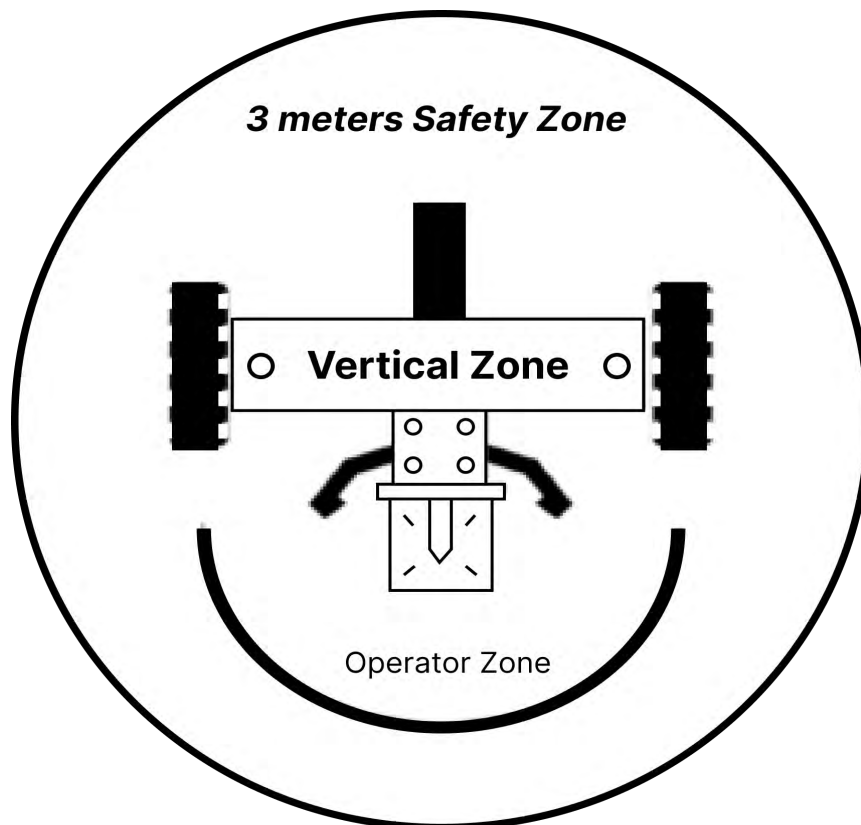

It is important to follow the below check-list before operating the machine:

- Read the Operations Manual carefully to understand the risks associated with using the log splitter.
- Ensure that the machine is operated in a well-ventilated environment.
- Wear appropriate protective gear to protect your hands, eyes, feet and body.

PREPARING THE LOGSPLITTER FOR USE

Before operating the logsplitter, make sure that both the supports legs are firmly set on the ground and that both the tires have been blocked.

This is necessary to prevent unnecessary movement of the log on the Logsplitter Splitting Table (10).

OPERATION INSTRUCTIONS

Proper Operation of the Log Splitter

Always follow Operational warnings & check-list before operating!

1.) Carefully place a log on the Splitting Table (10). Maximum length of the log suitable for the logsplitter is 60cm.

2.) Start Engine by using the following instructions:

- a.) Turn the engine switch to 'ON' position.
- b.) Slide the choke lever away from the fuel tank to activate the choke.
- c.) Turn the fuel tap on.
- d.) Raise the engine revs by sliding the throttle lever away from the fuel tank. Always use full throttle when using the machine.
- e.) Pull the starter cord handle lightly until resistance is felt, then pull briskly.
- f.) When the engine starts to run, deactivate the choke by sliding the lever towards the fuel tank.

4.) Start the splitting procedure by pushing and holding the Control Valve Lever (7) forward. Please note the Splitter Wedge (8) only moves downward when you are holding the lever forward. When you let go of the Control Valve Lever (7) the Splitting Wedge (8) stops immediately for safety reasons.

5.) To return the Splitting Wedge (8) to its starting position, simply pull the Control Valve Lever (7) backwards. Please note the Splitting Wedge (8) returns back to the original starting position automatically after the Control Valve Lever (7) is returned to its neutral position. Also, please note that for safety reasons, the Splitting Wedge (8) stops approx. 3-4cm from the Splitting Plate.

6.) Always make sure that the operator zone is clean and free from split wood and debris.

7.) Repeat the above steps as required.

WARNING

Towing incorrectly is a serious risk and can result in injury or death.

Please read the following Towing Warnings:

Remember to turn the engine and fuel tap to the off position prior to towing. This is to prevent flooding of the engine.

- **IMPORTANT: Log Splitter is not approved or designed to be towed on Public Roads.**
- **Serious injury or death can occur if Towing Safety Rules are not followed.**
- **Review Towing Safety Warnings as mentioned in your Owner's Manual.**
- **Drive safely. Be aware of the added length that the lifter splitter adds to your vehicle.**
- **Never ride on or transport cargo on the lifter splitter.**
- **Always secure and lock the lifter splitter to the vehicle hitch before towing.**
- **Drive the vehicle only after the lifter splitter is securely attached.**
- **Turn off the vehicle if leaving the lifter splitter unattended.**
- **Choose a leveled surface to operate the lifter splitter.**
- **Block the lifter splitter's wheels to prevent any unattended movement.**
- **Never tow or operate this splitter while under the influence of alcohol, drugs or medication.**
- **Avoid large holes and ditches when towing the lifter splitter in a vehicle.**
- **Always tow at a reduced speed on rough or uneven terrains, along the side of creeks, ditches and hillsides.**
- **Do not exceed a speed of 45KM/H when towing the lifter splitter.**
- **Read the below details to know further instructions regarding the logsplitter.**

TOWING THE LOGSPLITTER

The RedGum Super VHD 32000 Logsplitter has a 50mm Ball Coupler with a tow bar (3) which can be attached to the back of your ATV or Ride On Mower to tow the machine around your property. This tow bar is attached to an efficient Jockey Wheel, which allows you to easily move the machine without any problems! The RedGum Super VHD 32000 Logsplitter is not suitable for towing on the road. The logsplitter is only suitable for low-speed towing around your property. The maximum rated towing speed for the RedGum Super VHD 32000 Logsplitter is 45km/h.

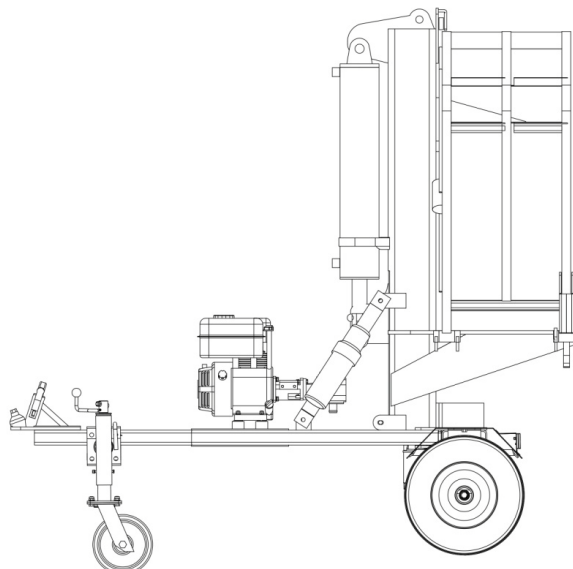

LOGSPLITTER COMPONENTS

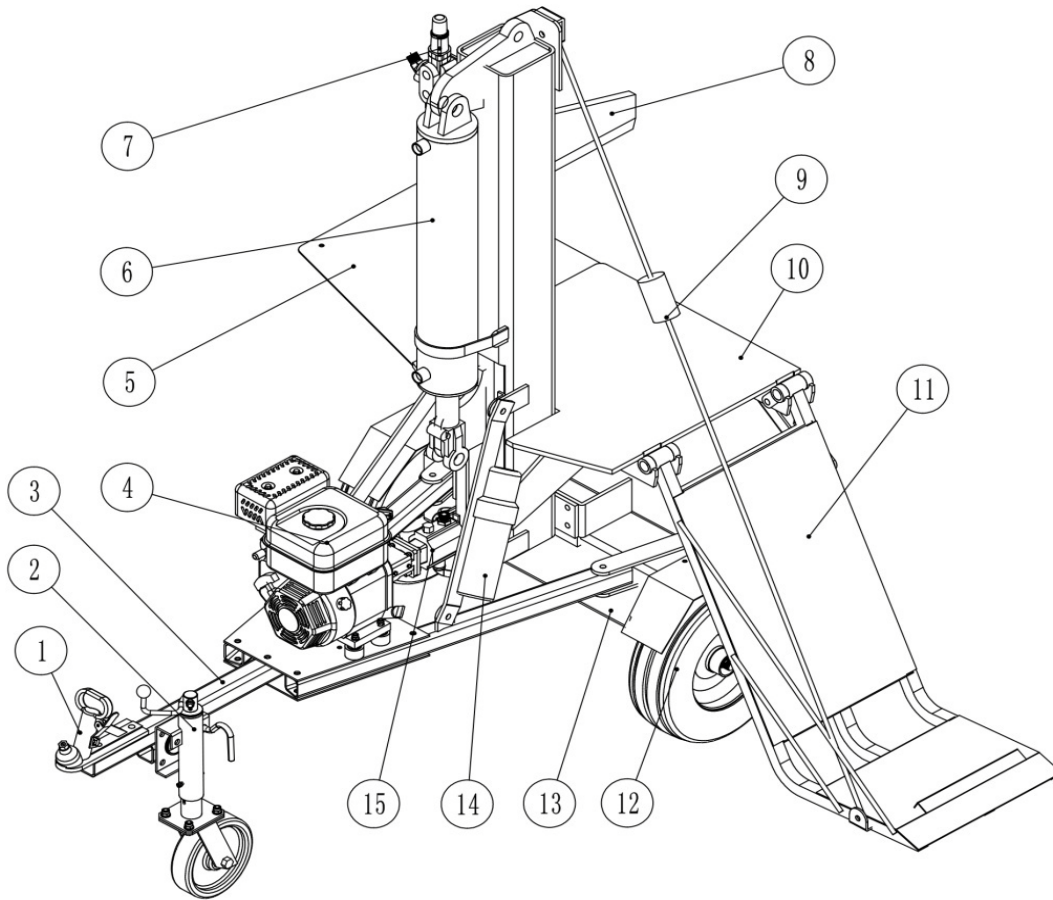

- 1) **Coupler:** Attaches the log splitter to the ball.
- 2) **Jockey Wheel**
- 3) **Tow Bar**
- 4) **Engine:** The air-cooled Honda GX200 powers the hydraulic pump
- 5) **Wood Tray:** Can hold a maximum of 75kgs
- 6) **Hydraulic Cylinder:** Internal diameter of 4.5 Inch
- 7) **Control Valve Lever:** Controls the forward and backward movement of splitting wedge.
- 8) **Splitting Wedge:** Features wedge wings and tapered ends making splitting easier.
- 9) **Counterweight Wire**
- 10) **Splitting Table**
- 11) **Hydraulic Lifting Plate**
- 12) **Tires:** 16" heavy-duty wheels capable of maximum speed of 45km/h (note this log splitter is not suitable for road towing)
- 13) **Oil Tank: 20L**
- 14) **Tool Box**
- 15) **Gear Pump:** Pumps the hydraulic oil through the system.

ENGINE COMPONENTS

- 1.) Fuel Cap
- 2.) Fuel Tank
- 3.) Oil Drain Plug
- 4.) Oil Filler Cap/Dipstick
- 5.) P.T.O Shaft
- 6.) Muffler
- 7.) Spark Plug
- 8.) Choke Lever
- 9.) Fuel Valve Lever
- 10.) Starter Grip
- 11.) Recoil Starter
- 12.) Air Cleaner

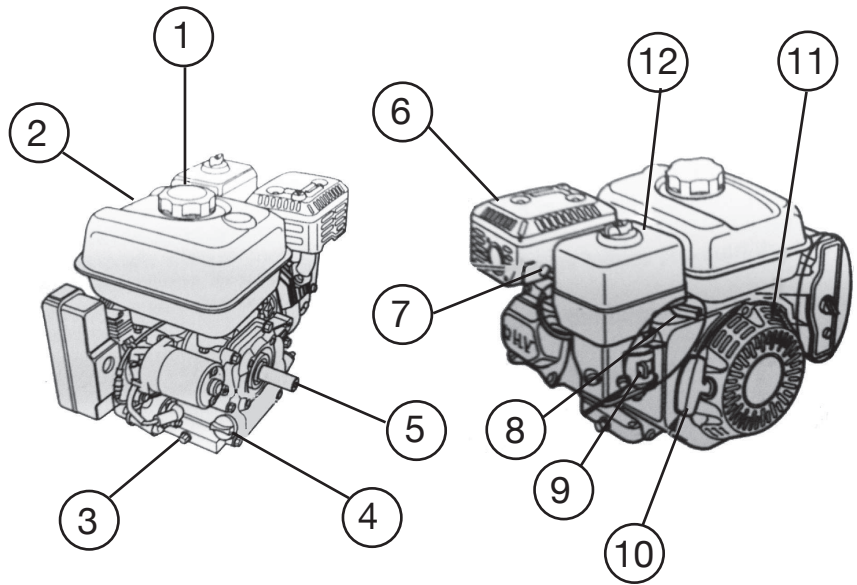

For more information on Engine Operation & Engine Maintenance, please refer to engine manual supplied with the log splitter.

LOGSPLITTER SPECIFICATIONS

Splitting Force.....	32000 kgs
Cycle Time.....	14 seconds
Hydraulic Tank capacity.....	20L
Max. Log Length.....	60cm (24")
Maximum Pressure.....	3000PSI
Gear Pump.....	11GPM, 2-Stage
Wheel Size.....	16"
Tow Bar Hitch Type.....	50mm Ball Coupler
Jockey Wheel.....	6"
Lifting Capacity.....	Up to 100kgs
Max. Towing Speed.....	45km/h
Hydraulic Filtration Capacity.....	25 microns

MAINTENANCE, STORAGE & ESSENTIAL CHECKS

Before performing maintenance, the log splitter must be placed in maintenance mode. To do so, follow the below steps:

- 1.) Turn off engine
- 2.) Move the Control Valve Lever forward and backward to relieve **Hydraulic Pressure** and leave in neutral position.
3. After performing maintenance, make sure all guards, shields and safety features are put back in place. Failure to follow this warning can result in serious injury.

MAINTENANCE SCHEDULE

COMPONENT	L/S	C/S	Interval			
			1	2	3	4
Complete Unit	Yes	Yes	I	I	I/C	I
On Off Switch	Yes	Yes	I	I	I	I
Choke/Primer	Yes	Yes	I/A	I	I/A	I
Engine Oil	Yes	Yes	I	R	R	I
Throttle Lever	Yes	Yes	I	I	I	I
Cables and Connections	Yes	Yes	I/A	I	I/A	I
Fuel Filter	Yes	Yes	I	I	R	
Carburettor	Yes	Yes	T	T	T	
Air Filter	Yes	Yes	I	I	C/R	I/C
Clutch	No	Yes	I	I	I	
Spark Plug	Yes	Yes	I	I/C	R	I
Cooling Fins	Yes	Yes	I	I/C	C	C
Starter Cord	Yes	Yes	I	I	I	I
Starter Housing Vents	Yes	Yes	I	I/C	C	C
Spark Arrestor	Yes	Yes	I	I	I/R	I
All Screws, Nuts & Linkage	Yes	Yes	I	I	I	I

COMPONENT	L/S	C/S	Interval			
			1	2	3	4
Anti Vibration Mounts	Yes	Yes	I	I	I	
Hydraulic Oil	Yes	No	I	I	I/R	I
Hydraulic Oil Pump	Yes	No	I	I	I	I/A
Hoses	Yes	No	I	I	I	I
Hydraulic Fittings	Yes	No	I	I	I/C	I/C
Beam	Yes	No	I	I	I	I
Control Valve	Yes	No	I	I	I	I
Belts	No	Yes	I	I	I/A	
Blades	No	Yes	I	I	I/R	
Flails/Hammers	No	Yes	I	I	I/R	

LEGEND: L/S = Log Splitter, C/S = Chipper Shredder
I = Inspect, T = Tune, R = Replace, C = Clean, S = Sharpen, A = Adjust, L = Lubricate

INTERVAL:

1 = Pre Delivery, 2 = First Service, 3 = Dealer Service, 4 = Every time the machine is used

DEALER SERVICE:

First service: 5 hours or 3 months (whichever occurs first)

Domestic Use = Every 12 months or 25 Hours (whichever occurs first)

Professional Use = Every 3 months or 100 Hours (whichever occurs first)

Storage of the Logsplitter

- Before storing, make sure the log splitter is clean and dry.
- Lightly lubricate all log splitter surfaces and moving parts to prevent rust.
- Store indoors or protected area and preferably under the RedGum Cover when the log splitter is not being used.
- **It is essential to fully retract the splitting wedge**, ensuring no silver part of piston rod is exposed to the elements.



WARNING

Skin Injection Hazard - Refer to your Engine Manual for further instructions

High pressure fluid can inject under the skin and can result in serious injuries!

- Make sure all hose and control fittings are tight before applying pressure. Relieve system pressure before servicing, as explained in point 2 at the top of the page.
- Do not check for leaks with your hand. Instead, place a piece of cardboard under the unit to check for leaks.
- If skin injection occurs, seek immediate 'Surgical Treatment'. Call 000.

RISK REGISTER

Level of Risk	Hazard	Dangers associated with the Risk	Measures to avoid/control this hazard
LOW	While assembling the Logsplitter, there is a risk of injury to the body due to lifting and installing of heavy components	Injury to back, Sore arms	Use the correct tools to assemble the logsplitter. Wear appropriate gloves while assembling the logsplitter.
LOW	While operating the logsplitter, there is a risk of fingers being jammed against the Splitting Table and the block of wood.	Injury to fingers and hand	Wear appropriate Safety Gear while operating the logsplitter. Only operate the machine within the defined Logsplitter Operating Zone.
LOW	While operating the logsplitter, there is a risk of falling over blocks of wood present in the Operating Zone	Injury due to fall, bruises and sprains	Make sure that only the operator of the machine is present in the defined Logsplitter Operating Zone. Wear appropriate Safety Gear while operating the logsplitter.
LOW	While operating the logsplitter, there is a risk of inhaling the exhaust fumes of the engine	Nausea	Make sure to only operate the machine in an outdoor environment, and within the defined Logsplitter Operating Zone.
LOW	While operating the logsplitter, there is a risk of getting burned by hot oil from the engine	Burns on the operator's skin	Wear appropriate Safety Gear while operating the logsplitter. The Oil Hoses on the logsplitter have Burst Protection for added safety
LOW	Maintenance and Troubleshooting of the Logsplitter		Read the Engine Manual and Operations Manual carefully before Maintenance and Troubleshooting of the machine.
LOW	Preparing the logsplitter for towing		To prevent fatigue or body strains, the RedGum Super VHD 32000 Logsplitter is equipped with a Tow bar and Coupler for easily attaching it to the back of your ATV or Ride On Mower. This machine is not suitable for road-towing and should only be towed around your property. The maximum rated towing speed for this machine is 45km/h

RedGum Logsplitters are safe and efficient machines, and are the best at getting the job done. Our machines utilize the latest innovations in technology to give you a safe yet comfortable wood-splitting experience. The above Risk Register provides you with a list of some risks associated with operating this logsplitter. Make sure to read the Operations Manual and Engine Manual carefully before operating this logsplitter, and wear appropriate Safety Gear at all times.

LOG SPLITTER TROUBLESHOOTING

Problem	Solution
Cylinder rod & splitting wedge will not move	Solution: A, D, E, H, J
Slow cylinder shaft speed when extending or retracting	Solution: A, B, C, H, I, K, L
Wood will not split or splits extremely slowly	Solution: A, B, C, F, I, K
Engine bogs down during splitting	Solution: G, L
Engine stalls under low load condition	Solution: D, E, L, M

Cause	Solution
A - Insufficient oil to pump	Check oil level in reservoir
B - Air in oil	Check oil level in reservoir
C - Excessive pump inlet vacuum	Check pump inlet hose for blockage or kinks
D - Blocked hydraulic lines	Flush & clean the splitter hydraulic system
E - Blocked control valve	Flush & clean the splitter hydraulic system
F - Low control valve setting	Adjust control valve with a pressure gauge
G - High control valve setting	Adjust control valve with a pressure gauge
H - Damaged control valve	Return control valve for authorised repair
I - Internal control valve leak	Return control valve for authorised repair
J - Internal cylinder leak	Return cylinder for authorised repair
K - Internally damaged cylinder	Return cylinder for authorised repair
L - Engine control out of adjustment	Return for authorised repair
M - Engine is loaded during idle down mode	Use shorter log length (24" or less) to allow engine to speed up before contact

WARRANTY AND SERVICE INFORMATION

Congratulations on the purchase of your new RedGum product. RedGum Products will assist you to complete the “job at hand” in an economical, safe and efficient manner.

This brochure explains the Warranty and Maintenance information for your product. This combined with your Owner’s Manual and the knowledge and expertise offered to you by your respective RedGum Dealer should provide you with the confidence that your decision to purchase a RedGum product was a good one.

STATEMENT OF WARRANTY

This statement of warranty applies to all RedGum products (offered by the manufacturer, RedGum Products). The manufacturer provides this warranty to the initial purchaser of this product (who has purchased it from an authorised RedGum Products dealer) for a period commencing from the date of purchase.

If the product is found to be defective, in RedGum Products’ opinion (due to a fault of the manufacturer) within the Warranty Period, RedGum Products will carry out the repair or replacement to the customer Free of Charge, provided:

- The fault is reported directly to the place of purchase.
- Sufficient proof of purchase is provided.
- The fault is not caused by misuse, neglect or incorrect adjustment by the user.
- The failure has not occurred through normal wear and tear.
- The product has not been serviced, repaired or alterations made by any one not authorised by RedGum Products to do so.

The Warranty Periods

The warranty periods mentioned below commence on your date of purchase:

Customer Type	RedGum Splitter	RedGum Chipper	<i>NOTE:</i>
Private/Domestic	24 months	12 Months	- Engines are covered by the respective original equipment manufacturers warranty and claims are made direct to the manufacturer agent.
Commercial	3 months	3 Months	- Replacement parts and accessories fitted during a repair under terms of warranty will enjoy cover for the remainder of the warranty period of the finished product.

Please note that Warranty Claims for your RedGum product can only be made through an Authorised RedGum Dealer

WHAT IS NOT COVERED BY WARRANTY

The following items are not covered by this warranty:

- Normal maintenance items which become worn through use, including, but not limited to, belts, blades, oil, blade adapters, filters, rewind springs, spark plugs, starter ropes, clutches and sprockets.
- Natural discoloration of material due to sunlight.
- Engines not manufactured by RedGum Products, these items are covered by the respective original equipment manufacturers' warranty, all claims must be sent to the appropriate manufacturer's agents.
- Using stale or contaminated fuel in the product.
- Damage or failure caused by accident, misuse and/or neglect, including, ingress of dirt, abrasives, moisture, rust & corrosion, and damage due as a result of inadequate maintenance.
- Failure to operate or maintain the unit in accordance with the Owners/Operators manual, this handbook or instruction given by a RedGum dealer.
- Alterations or modifications that change the intended use of the product or affect the product's performance, operation, safety or durability, or causes the product to fail to comply with any applicable laws.
- Damage due to incorrect usage such as incorrect log placement (as shown in the product's respective Owner's Manual)
- Additional damage to parts or components due to continued use occurring after any of the above.

ITEMS FOR WHICH A CHARGE WILL BE MADE

The following list is a guide to the types of items for which a charge will be made (unless failure is caused by a defect in the manufacturer's materials or workmanship).

Service: Maintenance servicing and all parts and fluid replaced in line with the maintenance schedule shown in this handbook.

Mechanical Adjustments: Including engine tuning, adjusting brakes, belts & clutches etc.

Drive System: Sprockets, belts, clutches, pulleys and bearings all wear and will require replacement.

Cutting Equipment: Blades, cutting discs and hammers wear during use and sharpening/replacement is required as a matter of normal maintenance.

Spark Plugs: Periodic replacement is required to ensure maximum engine performance and best fuel economy.

Induction/Combustion System: The removal of deposits and cleaning may be required from time to time and should be performed as necessary.

Tyres: Tyres are subject to wear and if they come in contact with external objects, they can deflate. A flat tyre is not a warrantable item.

External Surfaces, Paint, Trim and other Appearance items: Are affected by normal wear and tear and exposure to environmental conditions. A charge will be made for paint and trim items that require attention due to causes outside the manufacturer's control.

Hydraulics: Changing hydraulic fluids

The frequency of replacement, repair or adjustment will depend mainly on where and how you use your product, weather, atmospheric and environmental conditions and frequency of use.

CUSTOMER RESPONSIBILITIES

The customer must provide to an authorised RedGum Dealer their proof of purchase information such as a receipt.

The product must exhibit reasonable care in the maintenance, operation, storage and general upkeep practices as explained in the maintenance section of the Owners/Operators Manual or this handbook. This includes the whole product or any general wear item or component on the product. Any costs incurred to obtain warranty consideration or services is the customer's responsibility, including shipping and handling, travel expenses, lost time, lost production or pickup and delivery.

YOUR RIGHTS AS A CUSTOMER

The New Product Warranty that is provided by RedGum Products is in addition to the rights and remedies conferred on consumers by the relevant authorities and/or legislation. The warranty does not affect those rights or remedies, except to the extent that their application may lawfully be excluded. Any consequential, direct or incidental loss or damage is not covered by the warranty. Any statutory or other rights or remedies available in connection with a claim for such loss or damage should be pursued separately.

WHERE TO GO FOR WARRANTY REPAIRS

Take your product to any authorised RedGum Dealer if it needs warranty repairs. All authorised RedGum Dealers will honour the New Product Warranty, and will repair, replace or adjust free of charge any part of your product that is defective in factory materials or workmanship. Please note that RedGum is unable to reimburse the cost of repairs carried out during the warranty period by a repairer who is not an Authorised Servicing Dealer.

RedGum Products

WARRANTY INFORMATION

Please note down for future reference:

Machine: RedGum Super HDV 32000 Vertical Logsplitter

Customer Name:..... **Phone No.:**.....

Address:.....

Date of Purchase:.....

Serial Number:.....

Engine Number:.....

Dealer Name:.....

To find your nearest Authorised RedGum Products dealer,

Visit www.RedGumProducts.com.au or Call Toll-free 1300 039 251

The manufacturer reserves the right to make improvements in design and/or changes in specifications at any time without incurring any obligation to install them on units previously sold.

NOTES

.....
.....
.....
.....
.....

ACCESSORIES AVAILABLE

1.) RedGum Hydraulic Oil (Fluid 46 5L) - RRP \$49.75

High quality hydraulic oil fluid - ideal for topping up your RedGum logsplitter's hydraulic reserve, when required.



2.) RedGum WorkTable & Heavy Duty WorkTable

Improves productivity by preventing split logs from falling to the ground. It also helps reduce the effort of picking up split logs that require further splitting. Compatible with most RedGum splitters.

WorkTable - \$99, Heavy Duty WorkTable - \$129 (pictured)

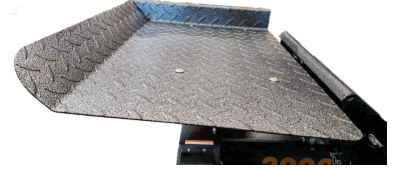

3.) RedGum Logsplitter Dust Cover - RRP \$99

Heavy-duty 200D logsplitter cover for superior protection against dust, dirt and heavy rain!



4.) RedGum Log Turn Table - RRP \$329

Our Patented Turn Table accessory fits all RedGum Log Splitters and allows for easy turning of heavy logs (for repeat splitting) when in vertical position.



5.) Dual Purpose Log Lifter & Roller - RRP \$189

This dual purpose log lifter & roller allows you to effortlessly roll large logs and keep them off the mud! Sturdy dual-foot design prevents the handle from digging into the ground.



6.) RedGum Vertical Splitting Plate - RRP \$179

A new innovation by RedGum, this accessory is compatible with most non-lifter RedGum logsplitters. As an alternative to the Log Turn Table, this stationary plate makes vertical splitting of logs super simple and pain-free!



RedGum Products

For more information contact your local RedGum Dealer

Visit: www.RedGumProducts.com.au

Phone: 1300 039 251



Follow us on Facebook: www.facebook.com/redgumproducts