

RedGum Yard & Garden

Owners Manual & Safety Instructions

Vacuum



RedGum Products

For more information contact your local RedGum Dealer
Phone 1300 039 251

Visit: www.RedGumProducts.com.au

Follow us on Facebook: www.facebook.com/redgumproducts



**WARNING: All operators must carefully read
this manual before operating this machine.**

Table of Contents

WARNING	3
IMPORTANT SAFETY INFORMATION	3
OPERATION OF THE MACHINE	4
SOUND AND VIBRATION	4
SAFETY DECALS	5
OPERATION INSTRUCTIONS	5
FUELING THE UNIT	5
PRE-OPERATION CHECKS	7
CHECKING THE OIL	7
ADJUSTING THE INTAKE HOUSING HEIGHT	7
OPERATION INSTRUCTIONS	7
CHANGING THE VACUUM HOSE	8
DRIVING THE MACHINE FORWARD	9
USING THE DEBRIS BAG	9
VACUUM COMPONENTS	10
ENGINE COMPONENTS	11
VACUUM SPECIFICATIONS	12
RISK REGISTER	13
MAINTENANCE AND WARRANTY INFORMATION	14-16
NOTES	17

WARNING

Read and thoroughly understand all instructions contained in this operation manual before operating this RedGum Vacuum.

Serious injury or death can result if safety instructions are not understood or followed. If you wish to discuss this machine's operational procedures after reading this manual, please call our Customer Service on 1300 039 251, available Monday to Friday, from 9AM to 5PM AEDT.

IMPORTANT SAFETY INFORMATION

	This is the safety alert symbol . It is used to alert you to potential personal injury hazards. Obey all safety messages that follow this symbol to avoid possible injury or death
DANGER	DANGER indicates an imminently hazardous situation which, if not avoided, will result in serious injury or death
WARNING	WARNING indicates a potentially hazardous situation which, if not avoided, will result in serious injury or death
CAUTION	CAUTION indicates a potentially hazardous situation which, if not avoided, could result in minor or moderate injury

- Read this manual carefully. Be familiar with the controls and how to properly operate the machine.
- Never allow children to operate the machine.
- Never allow adults unfamiliar with these instructions to operate the machine.
- Make sure that people (especially children) or pets are not in the Working Area of the machine when it is in use. Stop the machine if anyone enters the Working Area.
- Keep in mind that the operator or user is responsible for accidents or hazards occurring to other people or their property.
- Use only accessories that have been approved by RedGum Products. Make sure that the provided instructions are followed when installing these accessories.
- Make sure that you wear appropriate Personal Protective Equipment (PPE) gear such as Gloves, Safety Glasses and Boots when operating this machine.
- Before operating this machine, always visually inspect the machine for wear or damage to parts. Replace any worn or damaged parts before using the machine.
- Replace faulty mufflers.
- Petrol is highly flammable. This machine should be refueled outdoors only. Do not smoke while refueling the machine.

OPERATION OF THE MACHINE

- Before starting the engine, make sure that the Traction Drive Lever has been disengaged.
- Do not operate the machine in a confined space where dangerous carbon monoxide fumes can collect.
- Operate the machine only in daylight or in good artificial light.
- Do not operate the machine on steep slopes.
- Do not put your hands or feet near or under the snout. Keep clear of the snout and blower tube at all times.
- Shut the engine off and wait until the impeller comes to a complete stop before moving or replacing the debris bag.

- Make sure that all the screws, bolts and nuts are screwed tight enough to ensure that machine is in a safe condition and does not rattle when operating.
- After using the machine, make sure that the engine has been given time to cooloff.
- Check the debris bag frequently for wear or deterioration.
- Make sure that any worn or damaged parts have been replaced before operating the machine.
- Keep extra care when handling petrol as petrol vapors can lead to fires or even explosions.

SOUND AND VIBRATION

- Sound pressure level - This unit had equivalent continuous A-weighted sound pressure at the operator ear of 97 dB(A), based on the measurements of identical machines as per the procedures described in EN11201.
- Sound power level - This unit has a sound power level of 107 dB(A), based on measurement of identical machines per the procedures described in EN11904.
- Vibration level - This unit has a maximum hand-arm vibration level of 6.4m/s^2 , based on measurements of identical machines as per procedures described in EN1033.

SAFETY DECALS

Safety and warning decals are located near any area of potential danger on the machine. Replace these decals if they are damaged or lost.



Keep this manual handy for future reference and re-read this Owner's Manual periodically.

OPERATION INSTRUCTIONS

Before operating, make sure to check the fuel and oil levels and remove any debris from the machine. Also, ensure that there are no people in the operator's working area and no debris which might clog up the machine.

FUELING THE UNIT

Under certain conditions, unleaded petrol is extremely flammable and highly explosive. A fire or explosion from the petrol can burn you and cause damage to your property and others around you.

- Fill the fuel tank outdoors only, in an open area. Fill the fuel tank only when the engine is cold and wipe off any extra petrol that might spill.
- Do not fill the fuel tank completely full. Add unleaded petrol to the fuel tank until the level is 1/4 to 1/2 inch (i.e. 6mm to 13mm) below the bottom of the filler neck. This empty space in the tank allows petrol to expand.
- Never smoke when handling petrol, and stay away from an open

flame or where petrol fumes may be ignited by a spark.

- Store petrol in an approved container and keep it out of reach of children.
- If a petrol dispenser nozzle is required to be used, keep the nozzle in contact with the rim of the fuel tank or container opening at all times until fueling is complete.

It is recommended to use Unleaded Petrol for this machine. Do not use petrol containing more than 10% ethanol because the fuel system could be damaged. Do not mix oil with petrol.

1. Park the machine on a level surface and make sure that the engine is completely stopped.
2. Allow the engine to cool.
3. Clean around the fuel tank cap with a cloth to remove any debris around it and take off the fuel tank cap.
4. Add unleaded petrol to the fuel tank, until the level is 1 inch below the bottom of the filler neck. Note that the extra space in the tank allows the petrol to expand freely. Do not fill the fuel tank completely.
5. Install the fuel tank cap and wipe off any petrol that may have spilled with a clean cloth.

This machine is shipped without any oil in the crank-case. To operate the machine, you must fill the crank-case with 20oz (i.e. around 591ml) of high quality 10W-30 oil. Attempting to run the engine without any oil will lead to severe damage to the engine. Also, never overfill the crankcase with too much oil.

PRE-OPERATION CHECKS

CHECKING THE OIL

1. Park the machine on a leveled surface and make sure that the engine is completely stopped.
2. Allow the engine to cool.
3. Clean around the oil dipstick with a clean cloth to remove any debris or oil accumulation.
4. Pull out the dipstick and wipe the metal end clean.
5. Slide the dipstick fully into the dipstick tube and tighten it.
6. Remove the dipstick and check the metal end.
7. If the oil level is too low, slowly pour oil into the dipstick tube to raise the level of the oil until it reaches the full mark.
8. Replace and tighten the dipstick once the oil has reached the required levels.

ADJUSTING THE INTAKE HOUSING HEIGHT

You can adjust the clearance between the air intake housing and the ground by moving the height adjustment control to your desired position. Set the height to low (L) for vacuuming hard surfaces such as sidewalks or driveways and to high (H) for thick, lush turf with a heavy covering of leaves or clippings. The vacuum will work best when you keep the intake as close to the ground and is practical for the task that you are performing.

1. To adjust the Intake Housing Height, first stop the engine completely.
2. Tip the machine slightly to the back to take the weight off the castor wheels.
3. Move the height adjustment control forward to lower the intake housing. Similarly, to raise the housing, move the height adjustment control backwards.
4. Return the castor wheels to the ground when the height has been adjusted to the desired levels.

OPERATION INSTRUCTIONS

The RedGum Yard and Garden Vacuum is supplied with two extra hoses - a Vacuum Hose and a Blowing Hose. Both of these hoses provide different usage methods and functions, as per your requirements.

CHANGING THE VACUUM HOSE

Follow the below steps:

1. Loosen the hand-wheel and then remove the vacuum snout.
2. Insert bump of the connecting seat into the U Groove and then tighten the hand-wheel, as illustrated in the diagram below.

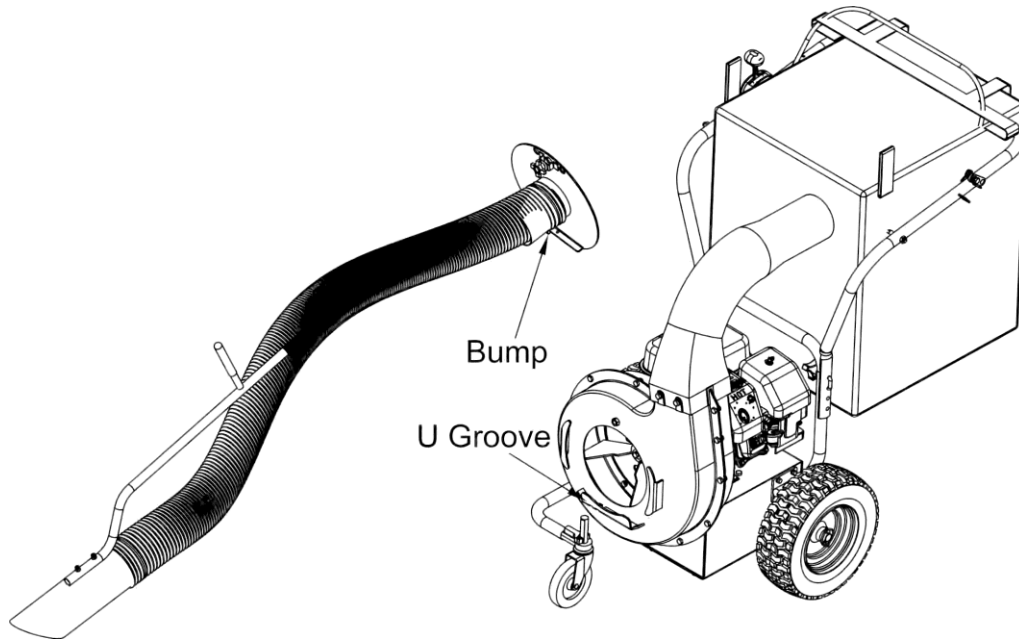

3. Attach the Blowing Hose to the ventilation pipe using the clamp, pass the screw of the connecting weldment through the hole in the frame tube and then tighten the nut according to the required blow angle. Illustration is as follows:

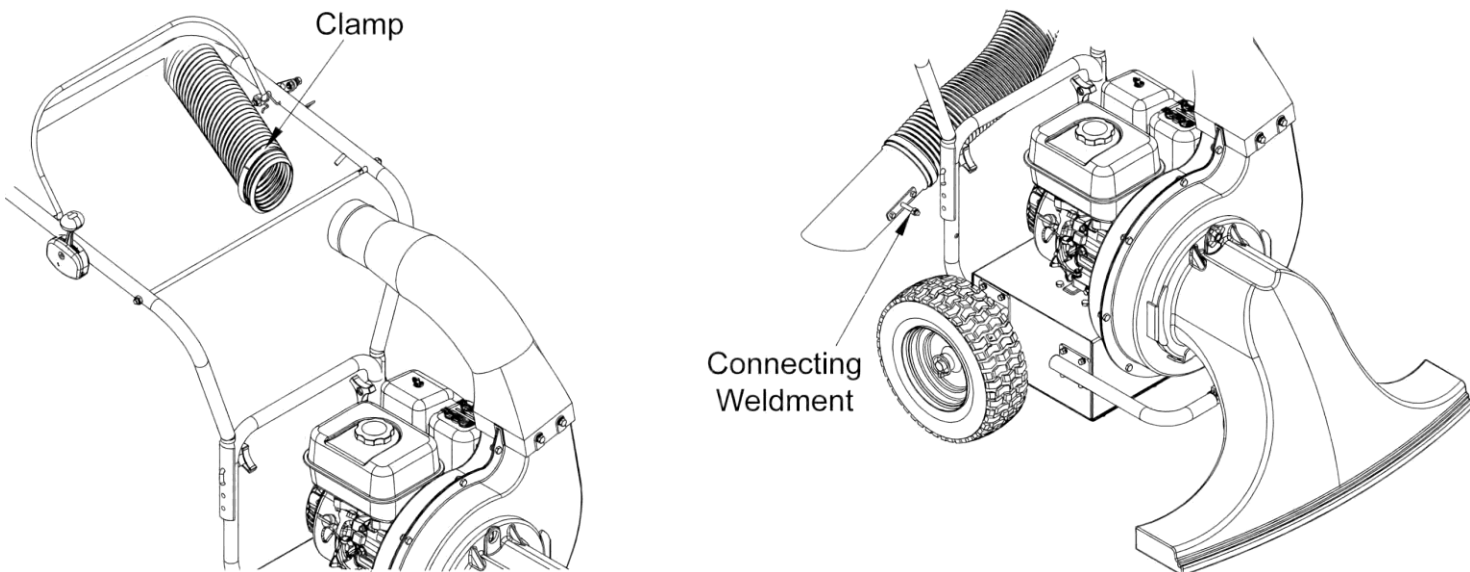

DRIVING THE MACHINE FORWARD

To accelerate the machine forward, simply hold the Traction Drive Level towards the handle. Release the Traction Drive Lever to stop the forward motion.

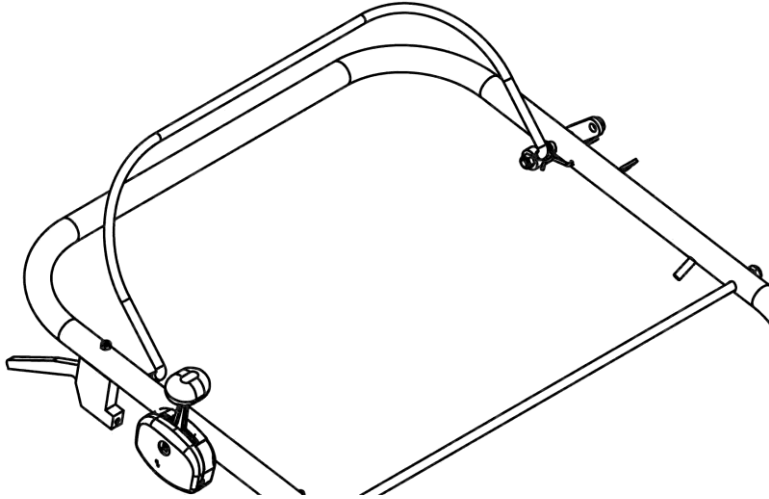

USING THE DEBRIS BAG

The debris bag has a zippered vent. When vacuuming an area which does not have a lot of dust, open the side vents to allow extra ventilation of air. When the area being vacuumed has a lot of dust, close the vent.

When the Debris Bag is full, empty the bag as follows:

1. Drive the vacuum to the location where you would like to dump the debris.
2. Stop the engine and make sure that it is completely off.
3. Un-zip the rear of the bag and dump the contents.



4. Close the zipper on the bag.

A worn debris bag could allow small debris to be thrown towards the operator which could result in injury or death. Check the debris bag frequently for wear and tear. If damaged, install a new debris bag.

NOTE: Debris Bag is a normal replaceable wear item. Contact your local RedGum dealer for further details.

VACUUM COMPONENTS

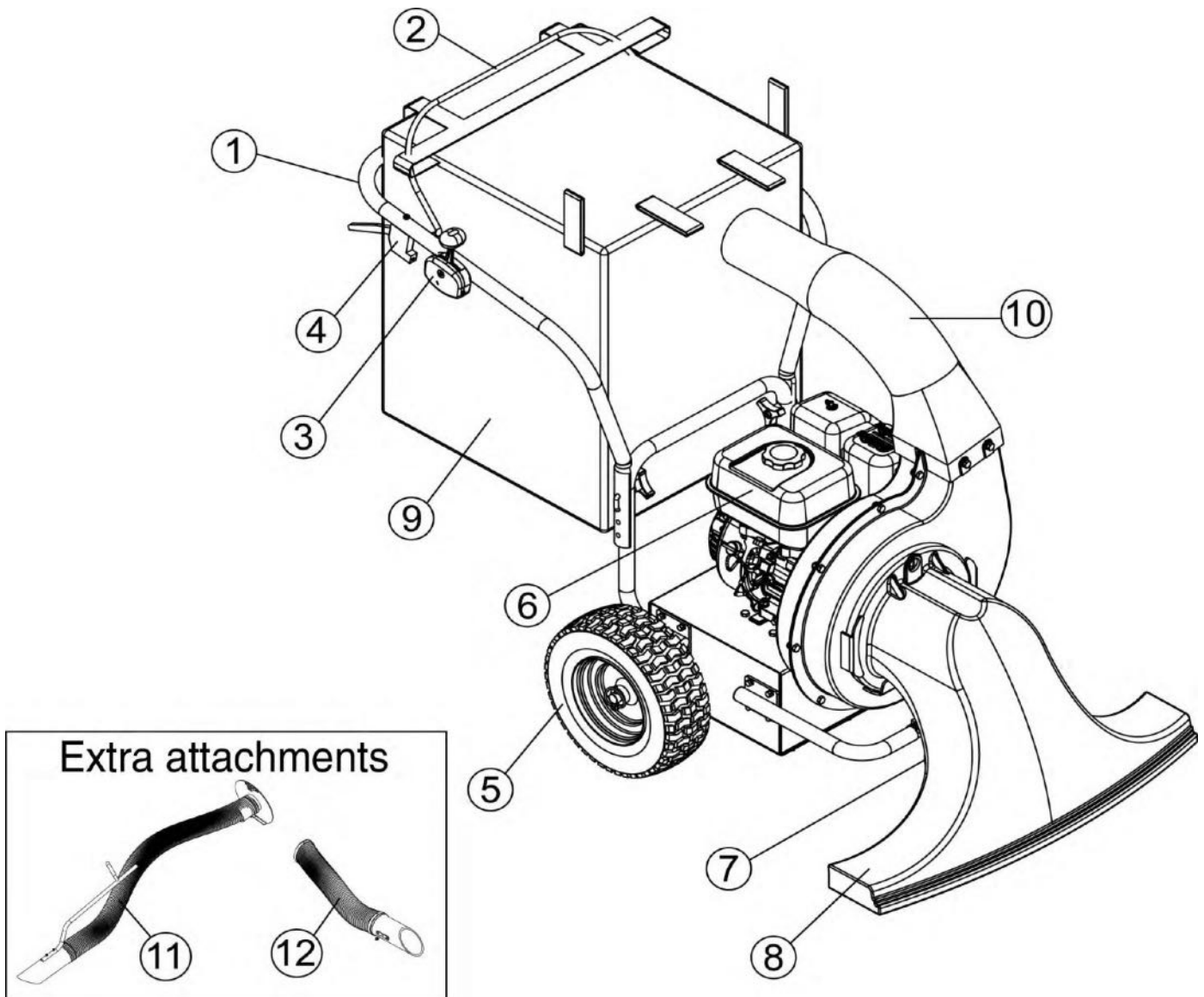

1. Push Handle
2. Traction Drive Lever
3. Throttle Switch
4. Caster Height Adjustment Handle
5. Wheel
6. Engine: 4-Stroke Honda GX200 OHV Petrol Engine
7. Swivel Caster
8. Vacuum Snout
9. Debris Bag
10. Ventilation Pipe
11. Vacuum Pipe Assembly
12. Blowpipe Assembly

ENGINE COMPONENTS

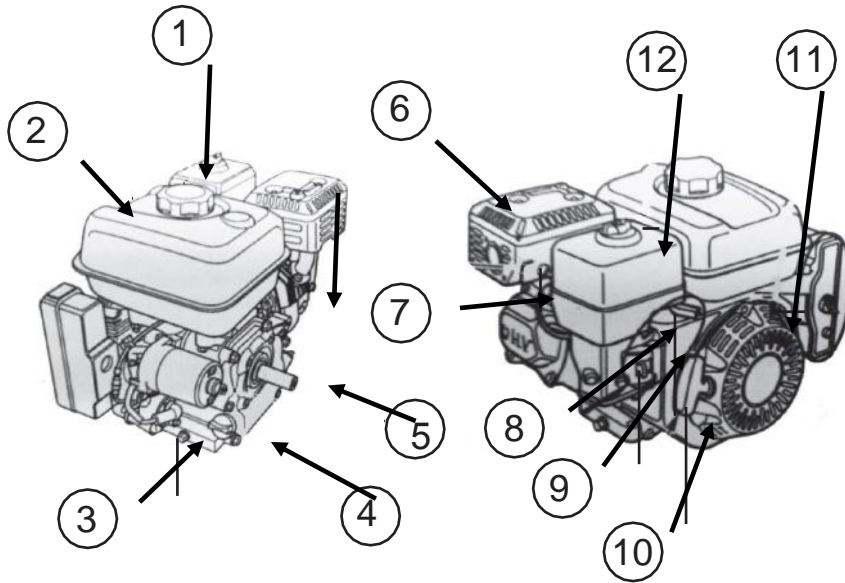

1. Fuel Cap
2. Fuel Tank
3. Oil Drain Plug
4. Oil Filler Cap/ Dipstick
5. P.T.O Shaft
6. Muffler
7. Spark Plug
8. Choke Lever
9. Fuel Valve Lever
10. Starter Grip
11. Recoil Starter
12. Air Cleaner

For more information on Engine Operation & Engine Maintenance, please refer to the engine manual supplied with the vacuum.

VACUUM SPECIFICATIONS

Engine..... Honda GX200 4-Stroke OHV
Propelled Type..... Self-Propelled Variable Speed
Maximum Speed..... 2km/h
Wheel Size..... 7"/4.00 - 4 Jockey Wheel
Collection Bag Capacity.....40L
Starter..... Recoil Starter
Suction Capacity..... Approx. 3000 m³/h
Fuel Type and Tank Capacity..... 91 RON Unleaded, 3.6L
Warranty..... 1 Year Machine, 3 Year Engine Warranty

RISK REGISTER

Level of Risk	Hazard	Dangers associated with the Risk	Measures to avoid/control this hazard
LOW	While assembling the Vacuum, there is a risk of injury to the body due to lifting and installing of heavy components	Injury to back, arms and hands	Use the correct tools to assemble the Vacuum. Wear appropriate gloves while assembling the Vacuum Use proper lifting techniques Use assistance to lift components
LOW	While operating the Vacuum, there is a risk dust and small particles being blown out.	Injury to eyes	Wear appropriate Safety Gear while operating the Vacuum. Ensure debris bag is fully zipped and has no holes.
LOW	While operating the Vacuum, there is a risk off tipping the machine on rough and / or uneven ground	Injury due to fall, bruises and sprains	Make sure that only the operator of the machine is present in the defined Operating Zone. Keep machine on level ground and watch for unexpected holes and rocks that may affect the stability of the Vacuum Wear appropriate Safety Gear while operating the Vacuum.
LOW	While operating the Vacuum, there is a risk of inhaling the exhaust fumes of the engine	Nausea	Make sure to only operate the machine in an outdoor environment, and within the defined Vacuum Operating Zone.
LOW	While operating the Vacuum, there is a risk of getting burned by Exhaust from the engine	Burns on the operator's skin	Wear appropriate Safety Gear while operating the Vacuum. Keep clear of hot engine and engine exhaust
LOW	Maintenance and Troubleshooting of the Vacuum		Read the Engine Manual and Operations Manual carefully before Maintenance and Troubleshooting of the machine.

RedGum Products are safe and efficient machines, and are the best at getting the job done. Our machines utilize the latest innovations in technology to give you a safe yet comfortable experience. The above Risk Register provides you with a list of some risks associated with operating this Vacuum. Make sure to read the Operations Manual and Engine Manual carefully before operating this machine, and wear appropriate Safety Gear at all times.

MAINTENANCE SCHEDULE

Component	INTERVAL				
	DAILY	1	2	3	4
Complete Unit		I	I	I/C	I
On / Off Switch		I	I	I	I
Choke Primer		I/A	I	I/A	I
Engine Oil	I	I	R	R	I
Throttle Lever		I	I	I	I
Cables and Connectors		I/A	I	I/A	I
Fuel Filter		I	I	R	
Carburetor		T	T	T	
Air Filter		I	I	C/R	I/C
Clutch		I	I	I	
Spark Plug		I	I/C	R	I
Cooling Fins		I	I/C	C	C
Starter Cord		I	I	I	I
Starter Housing Vents		I	I/C	C	C
Spark Arrestor		I	I	I/R	I
Anti Vibration Mounts		I	I	I	
All Screws and Nuts		I	I	I	I
Debris Bag*	I/C				

Interval

- 1 Pre Delivery
- 2 First Service (5 hours of Operation or 3 Months, which ever occurs first
- 3 Annual by Dealer
- 4 Before Use inspection

Maintenance Type

I = Inspection
 C = Clean
 A = Adjust
 L = Lubricate
 R = Replace

NOTE: Debris Bag is a normal replaceable wear item. Contact your local RedGum dealer for further details.

WARRANTY AND SERVICE INFORMATION

Congratulations on the purchase of your new RedGum product. RedGum Products will assist you to complete the “job at hand” in an economical, safe and efficient manner.

This brochure explains the Warranty and Maintenance information for your product. This combined with your Owner’s Manual and the knowledge and expertise offered to you by your respective RedGum Dealer should provide you with the confidence that your decision to purchase a RedGum product was a good one.

STATEMENT OF WARRANTY

This statement of warranty applies to all RedGum products (offered by the manufacturer, RedGum Products). The manufacturer provides this warranty to the initial purchaser of this product (who has purchased it from an authorised RedGum Products dealer) for a period commencing from the date of purchase.

If the product is found to be defective, in RedGum Products’ opinion (due to a fault of the manufacturer) within the Warranty Period, RedGum Products will carry out the repair or replacement to the customer Free of Charge, provided:

- The fault is reported directly to the place of purchase.
- Sufficient proof of purchase is provided.
- The fault is not caused by misuse, neglect or incorrect adjustment by the user.
- The failure has not occurred through normal wear and tear.
- The product has not been serviced, repaired or alterations made by any one not authorised by RedGum Products to do so.

The Warranty Periods

The warranty periods mentioned below commence on your date of purchase:

	Residential	Commercial
Vacuum	1 Year	90 Days
Engine	3 Years	3 Years

NOTE:

- Engines are covered by the respective original equipment manufacturers warranty and claims are made direct to the manufacturer agent.

- Replacement parts and accessories fitted during a repair under terms of warranty will enjoy cover for the remainder of the warranty period of the finished product.

Please note that the Warranty Claims can only be made through an Authorised RedGum Dealer. Engine warranty is provided by Honda Australia. Check Engine Manual for Details & Exclusions.

WHERE TO GO FOR WARRANTY REPAIRS

Take your product to any authorised RedGum Dealer if it needs warranty repairs. All authorised RedGum Dealers will honour the New Product Warranty, and will repair, replace or adjust free of charge any part of your product that is defective in factory materials or workmanship. Please note that RedGum is unable to reimburse the cost of repairs carried out during the warranty period by a repairer who is not an Authorised Servicing Dealer.

Honda engine warranty repairs must be carried out by an Approved Honda Dealer.

RedGum Products

Visit www.RedGumProducts.com.au • Call 1300 039 251

WARRANTY INFORMATION

Please note down for future reference:

Model : RedGum Yard & Garden Vacuum (Honda GX200)

Date of Purchase:

Serial Number:

Engine Number:

Purchased from:

To find your nearest Authorised RedGum Products dealer , visit:
www.RedGumProducts.com.au or Call Toll Free 1300 039 251

RedGum does not reimburse or cover costs associated with freight or transport to/from an authorised RedGum Dealer. It is the responsibility of the customer to transport the unit to/from an Authorised RedGum Dealer.

The manufacturer reserves the right to make improvements in design and/or changes in specifications at any time without incurring any obligation to install them on units previously sold.

NOTES

A series of horizontal dotted lines for writing notes.

RedGum Yard & Garden Vacuum Illustrated Parts Listing (IPL)

RedGum Products

For more information, contact your local RedGum Dealer

Phone 1300 039 251

Visit: www.RedGumProducts.com.au

Follow us on Facebook: www.facebook.com/redgumproducts

Parts Drawing & Parts List

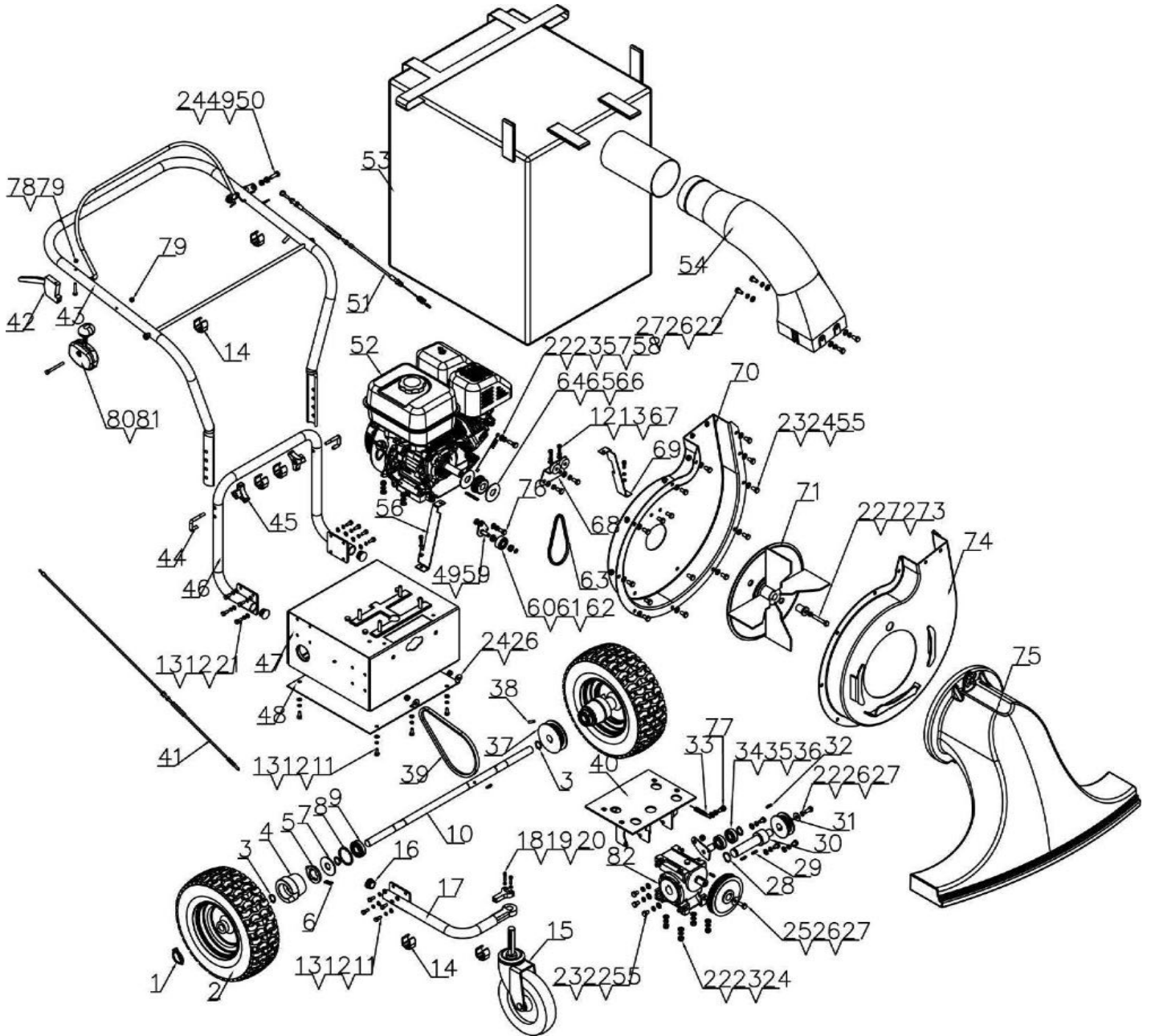

Parts Drawing & Parts List

Ref#	Drawing No.	Description	Qty
1	TS600-00009	Ring Type O Lock	2
2	NC6501-00010	Wheel	2
3	9304-20000-FH	Circlip for Shaft	5
4	NC6501-00009	Wheel Flange	2
5	NC65-00028	Ratchet	2
6	NC65-00024	Key	2
7	NC6501-00008	Tire Mounting Flat Pad Ø8	2
8	9304-47000-FH	Shaft Retaining Ring	2
9	NC6501-00017	Bearing	2
10	NC6501-00007	Wheel Axle	1
11	9101-06020-DX8.8	Hex Bolt M6x20	6
12	9306-06000-DX	Lock Washer Ø6	22
13	9301-06000-DX	Flat Washer Ø6	22
14	NC6501-00012	Line Buckle	7
15	NC6501-00013	Universal Wheel Assembly	1
16	NC6501-00030	Silencer	3
17	NC6501-07000	Front Wheel Bracket Welding	1
18	9105-05020-DX	Inner Six-stage Cylindrical Head Screw M5x20	2
19	9306-05000-DX	Lock Washer Ø5	2
20	NC6501-00021	Wheel Clutch	1
21	9101-06025-DX	Hex Bolt M6x25	12
22	9306-08000-DX	Lock Washer Ø8	25
23	9301-08000-DX	Flat Washer Ø8	30
24	9206-08000-DX	Nylon Lock Nut M8	23
25	NC6501-00002	Synchronous Driven Wheel	1
26	9302-08000-DX	Big Flat Washer Ø8	8
27	9101-08020-DX8.8	Hex Bolt M8x20	6
28	9304-25000-FH	Shaft Retaining Ring	1
29	8801-8x7x30	Flat Key	2
30	NC6501-00019	Gearbox Output Shaft	1
31	NC6501-00004	Multi-wedge Drive Wheel	1
32	5x5x20	Flat Key	3
33	NC6501-00024	Tensioning Spring 1	1
34	NC6501-03000	Tensioning Welded Parts	1
35	9603-6203	Bearing	2

36	9304-17000-FH	Shaft Retaining Ring	1
37	NC6501-00005	Multi-wedge Driven Wheel	1
38	9402-06025-FH	Elastic Cylindrical Pin	1
39	7-PJ-530	V-ribbed Belt	1
40	NC6501-02000	Gearbox Mounting Weldment	1
41	NC6501-00020	Wheel Clutch Cable	1
42	NC6501-00022	Handle	1
43	NC6501-09000	Handle Assembly	1
44	NC6501-00015	U-screw	2
45	N280-70000	Hand Wheel	2
46	NC6501-08000	Rear Bracket Welding	1
47	NC6501-01000	Engine Mounting Weldment	1
48	NC6501-00023	Bottom Sealing Plate	1
49	NC6501-00026	Mounting Washer	2
50	9101-08025-DX8.8	Hex Bolt M8x25	1
51	NC6501-00018	Tension Cable	1
52	/	6.5HP Engine	1
53	NC6501-00016	Debris Bag	1
54	NC6501-00014	Ventilation Duct	1
55	9101-08016-DX8.8	Hex Bolt M8x16	21
56	NC6501-00029	Protective Cover 2	1
57	NC6501-00025	Tensioning Spring 2	1
58	NC6501-00011	Spring Retaining Bolt	1
59	NC6501-11000	Timing Belt Tensioner	1
60	NC6501-00027	Bearing Washer	2
61	GB/T 296-3202	Bearing	1
62	9304-09000-FH	Shaft Retaining Ring	1
63	HTD570-5M-15	Timing Belt	1
64	8801-4.78x4.78x50	Flat Key	1
65	NC6501-00001	Synchronous Drive Wheel	1
66	NC6501-00003	Impeller Gasket	2
67	9105-06020-DX	Inner Six-stage Cylindrical Head Screw M6x20	4
68	NC6501-10000	Connecting the Welded Parts	1
69	NC6501-00028	Protective Cover 1	1
70	NC6501-05000	Chassis Back Plate Welding	1
71	NC6501-04000	Blade Welding	1
72	NC6501-00031	Crankshaft Compression	1

73	5/16-24UNF-2	Hex Bolt	1
74	NC6501-06000	Case Front Plate Welding	1
75	NC65-05000	Vacuum Snout	1
76	5/16-24UNF-4/5	Hex Bolt	3
77	NC6501-00032	Clutch Spring Bolt	1
78	9110-06055-DX	Cross Recessed Pan Head Bolt M6x55	1
79	9206-06000-DX	Nylon Lock Nut M6	2
80	9101-06065-DX8.8	Hex Bolt M6x65	1
81	TS6100-00029	Throttle Switch	1
82	NC6501-00006	Gearbox	1
