

48" / 54" TOW-BEHIND LAWN SWEEPER

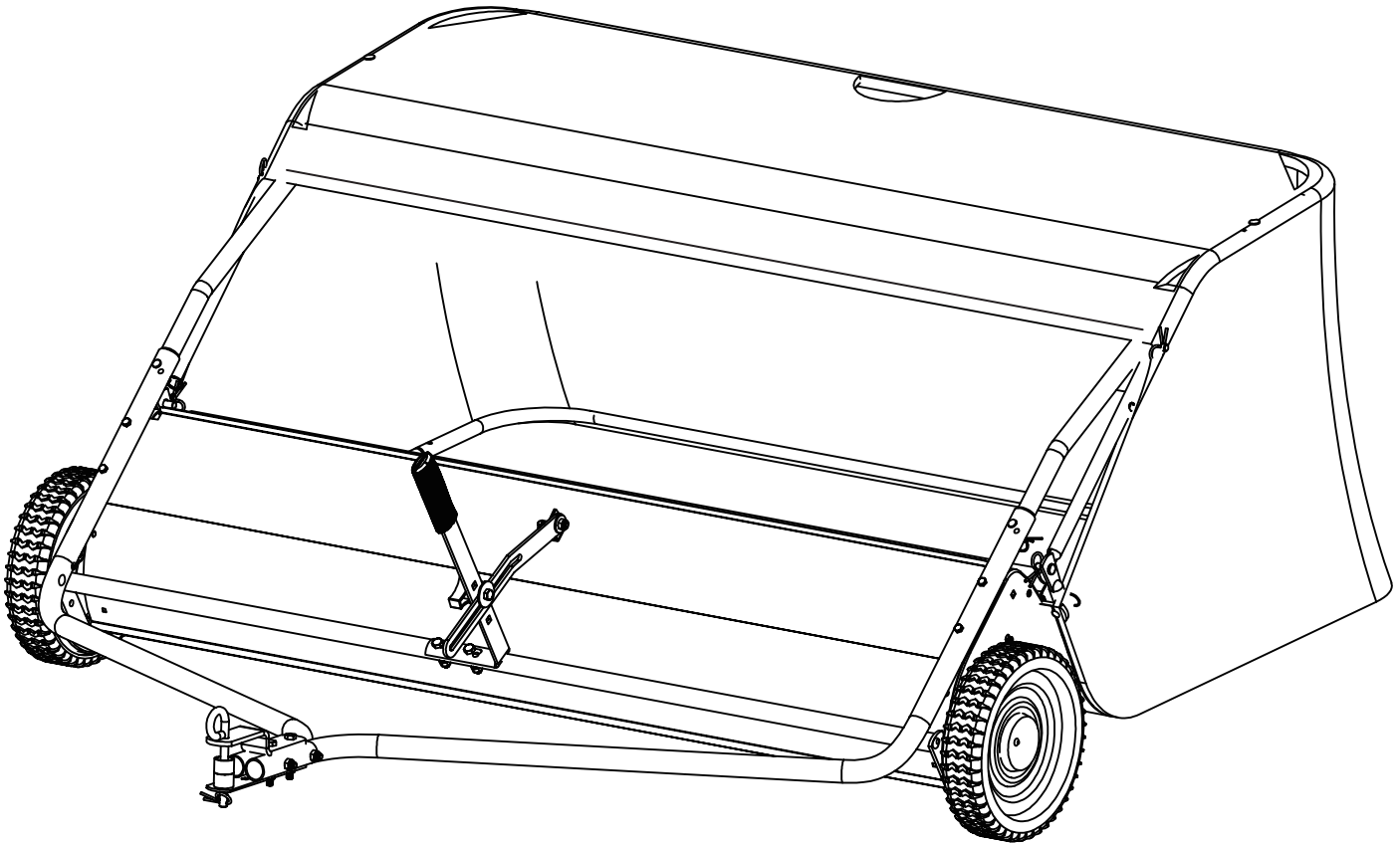

ATTACH YOUR RECEIPT HERE

Serial Number _____ Purchase Date _____

TABLE OF CONTENTS

| | |
|----------------------------------|---------|
| Package Contents | 3 |
| Hardware Contents | 4 |
| Safety Information | 5 |
| Assembly Instructions | 6 - 11 |
| Operating Instructions | 12 |
| Maintenance | 13 - 14 |
| Storage and Specifications | 15 |
| Parts Drawing | 16 |
| Parts List | 17 - 18 |

PACKAGE CONTENTS

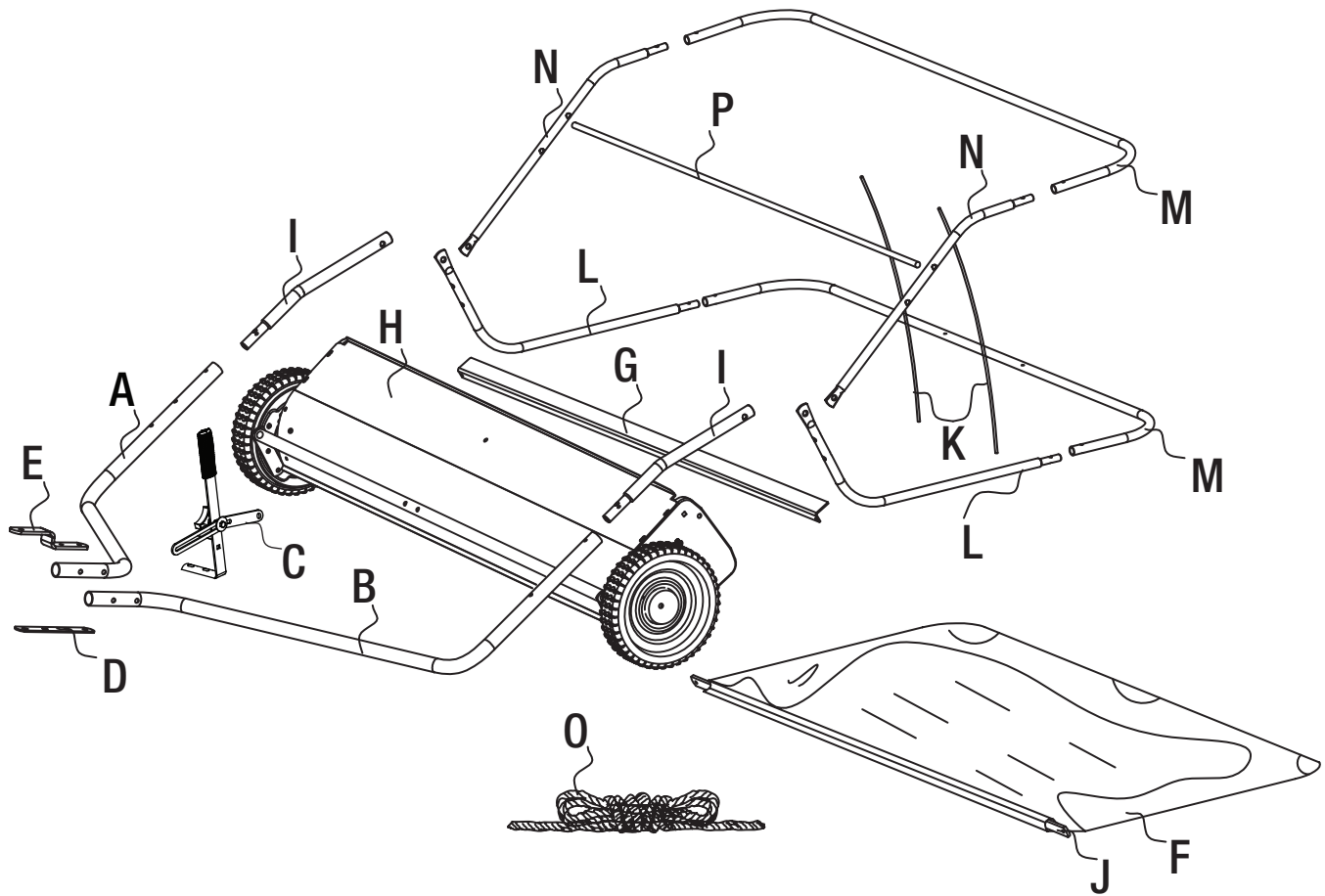

| PART | DESCRIPTION | QUANTITY |
|------|---------------------------|----------|
| A | Righthand Hitch Tube (RH) | 1 |
| B | Lefthand Hitch Tube (LH) | 1 |
| C | Handle Assembly | 1 |
| D | Straight Hitch Bracket | 1 |
| E | Hitch Bracket | 1 |
| F | Hopper Bag | 1 |
| G | Connecting Rod | 1 |
| H | Sweeper Housing Assembly | 1 |
| I | Bag Arm Tube | 2 |
| J | Bag Frame Strap | 1 |
| K | Hopper Support Rod | 2 |
| L | Lower Hopper Side Tube | 2 |
| M | Rear Hopper Tube | 2 |
| N | Upper Hopper Side Tube | 2 |
| O | Rope | 1 |
| P | Front Support Rod | 1 |

HARDWARE CONTENTS

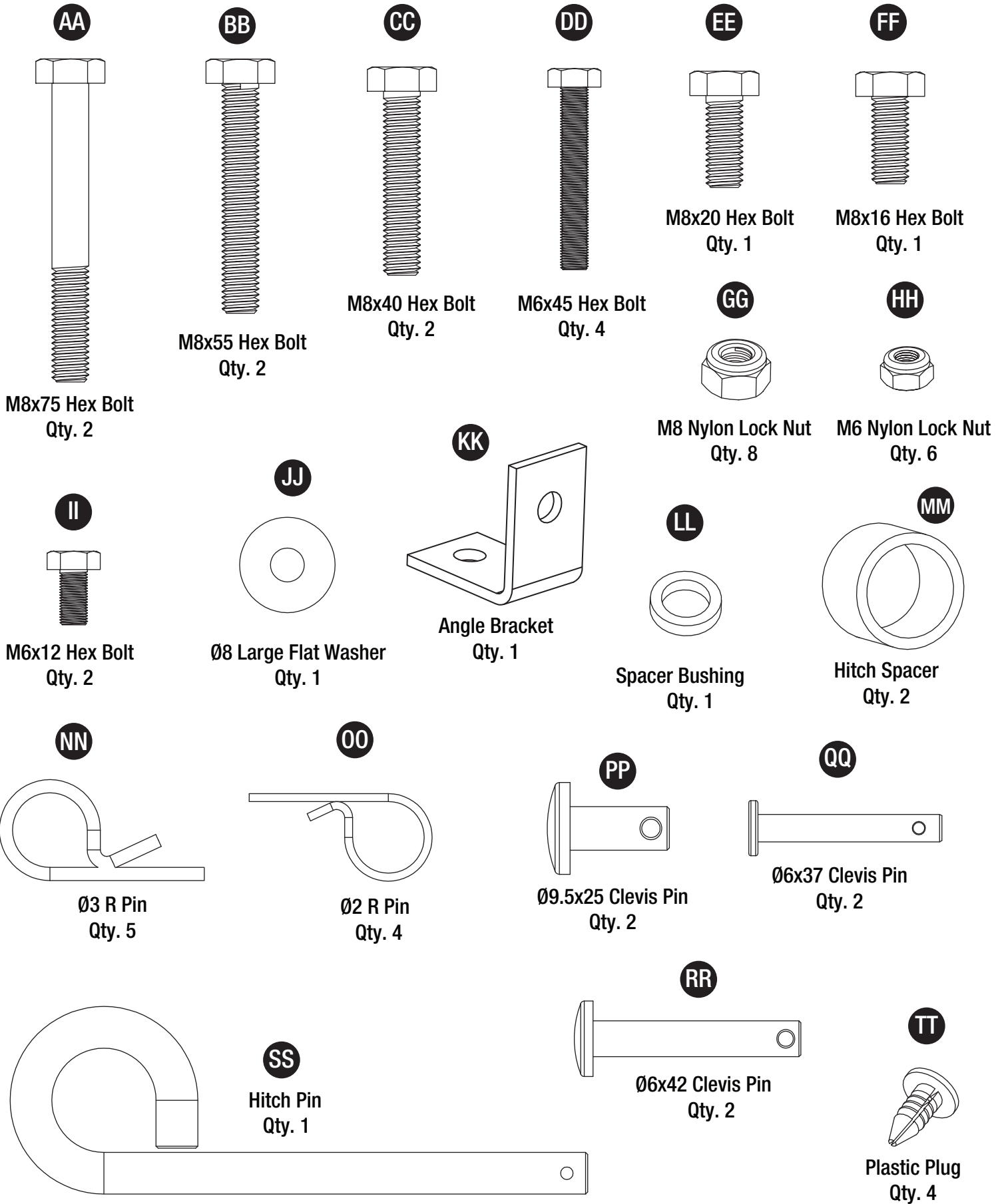

SAFETY INFORMATION

READ and **UNDERSTAND** this manual completely before using the Lawn Sweeper.

Operator must read and understand all safety and warning information, operating instructions, maintenance and storage instructions, before operating this equipment. Failure to properly operate and maintain the lawn sweeper could result in serious injury to the operator and/or bystanders.

- **Do not** use the sweeper to carry passengers and never sit or stand on the lawn sweeper.
- **Do not** allow children to play on, stand upon, or climb on the lawn sweeper.
- **Only** connect the hopper rope to the tow vehicle. Do not connect the hopper rope to anything else.
- **Always** keep body parts clear from and clothing detached from the sweeper and rope.
- **Always** inspect the sweeper before use to insure that it is in good working condition.
- Replace or repair damaged or worn parts immediately.
- **Always** check and tighten hardware and assembled parts before operation.
- **Avoid** large holes and ditches when operating the equipment.
- **Be careful** when operating the sweeper on steep grades (hills).
- **Always** operate up and down the slope. Never operate across the face of the slope.
- **Always** operate at reduced speeds on rough terrain, along creeks, ditches and on hillsides.
- **Do not** operate close to creeks, ditches, or public highways.
- **To avoid** personal injury and/or equipment damage **DO NOT EXCEED 5 MPH**.
- **Always** use caution when loading and unloading the hopper.
- **Only** tow with recommended vehicles (Lawn/Garden Tractors and ATVs).
- **Always** refer to the vehicle owner's manual for proper towing.
- Sweeper is not designed to be used with zero-turn mowers.
- **Always** secure and lock sweeper to the vehicle hitch before operating.
- **Always** keep hands and feet clear from moving parts while operating the equipment.
- **Always** clear and keep work area clean when operating.
- **Always** wear safety gear, eye protection, gloves, and work boots when operating the sweeper.



WARNING: The warnings, cautions, and instructions outlined in this instruction manual cannot cover all possible conditions or situations that may occur. It must be understood by the operator that common sense and caution are factors which cannot be built into this product and must be supplied by the operator.



WARNING: This product can expose you to chemicals including lead and lead compounds which are known to the State of California to cause cancer and birth defects or other reproductive harm. For more information, go to www.P65Warnings.ca.gov

PREPARATION

Before beginning assembly of product, make sure all parts are present. Compare parts with package contents list and hardware contents list. If any part is missing or damaged, do not attempt to assemble the product.



Tools Required for Assembly (not included): 10 mm, 13 mm and 14 mm Wrenches.

ASSEMBLY INSTRUCTIONS

1 Mount Angle Bracket

- Remove the four wood splints from brush. These can be loosened by hand or with a 10mm socket or wrench.
- Attach the Angle Bracket (KK) to the sweeper housing (H) by using the M8x16 Hex Bolt (FF) and the M8 Nylon Lock Nut (GG). Tighten securely, using 13 mm and 14 mm wrench.

Hardware Used

| | | | |
|-----------|-------------------|---|-----|
| KK | Angle Bracket |  | x 1 |
| FF | M8x16 Hex Bolt |  | x 1 |
| GG | M8 Nylon Lock Nut |  | x 1 |

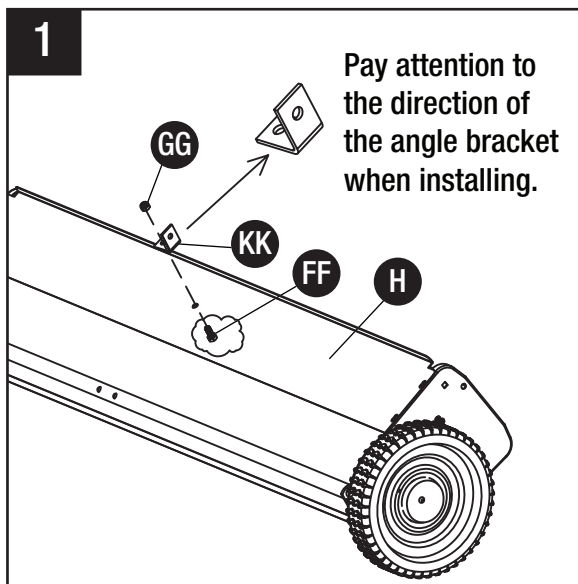

CAUTION: Before tightening, make sure the angle bracket is aligned straight with the sweeper housing, as shown in the diagram, with the raised end positioned on the opposite side of the main logo.

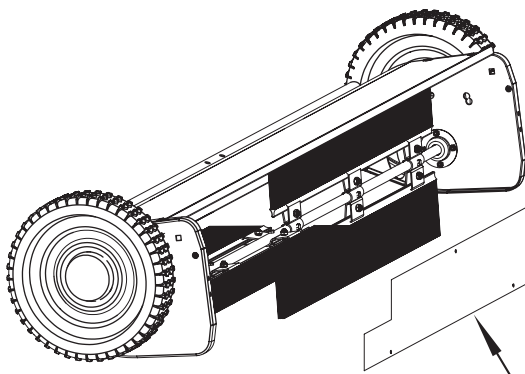



Four wood splints are used to protect the brushes during shipping.

2 Attach Hitch Tubes

- Remove the two black hitch tubes (A) & (B) from the box.
- Place righthand hitch tube (A) on the right side of the main housing (H) with the angled end facing inward.
- Place a M6x45 Hex Bolt (DD) through the middle hole in righthand hitch tube (A) and the top hole in the main housing (H).
- Fasten the bolt with a M6 Nylon Lock Nut (HH).
- Place another M6x45 Hex Bolt (DD) in the hole below the bolt you just secured.
- Fasten with another M6 Nylon Lock Nut (HH).
- Repeat these steps for lefthand hitch tube (B) on the other side. Tighten securely, using 10 mm wrench.

Hardware Used

| | | | |
|-----------|-------------------|---|-----|
| DD | M6x45 Hex Bolt |  | x 4 |
| HH | M6 Nylon Lock Nut |  | x 4 |

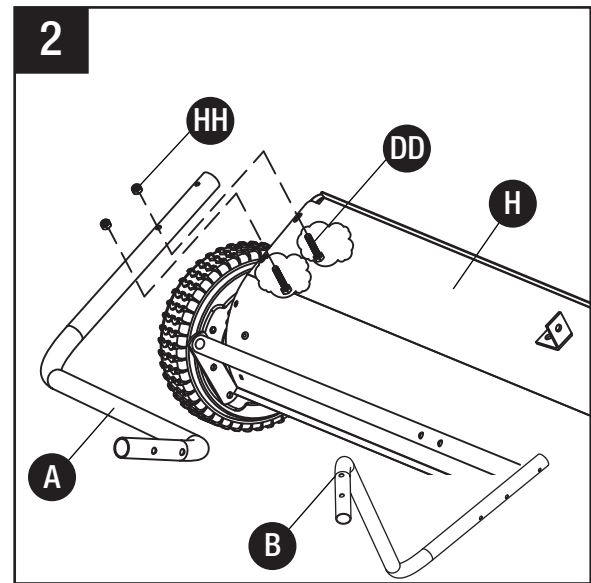

CAUTION: Right Hand (RH) and Left Hand (LH) refer to the drivers' orientation when operating the vehicle.

ASSEMBLY INSTRUCTIONS

3 Secure Hitch Tubes Together

- After attaching the hitch tubes. Secure the two ends together with two M8x75 Hex Bolts (AA) and two M8 Nylon Lock Nuts (GG).
- Tighten loosely for now, using 13 mm and 14 mm wrench.



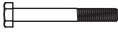

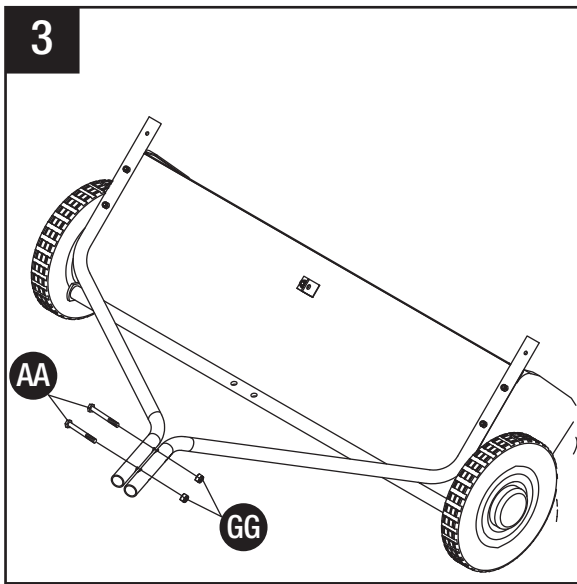
Hardware Used

| | | | |
|-----------|-------------------|---|-----|
| AA | M8x75 Hex Bolt |  | x 2 |
| GG | M8 Nylon Lock Nut |  | x 2 |



- Slide two M8x55 Hex Bolts (BB) through the two holes in the top of the bracket. Pass the bolt closest to the main housing through the gap between the two bolts in the hitch tubes.
- Fasten these bolts with two M8 Nylon Lock Nuts (GG) using 13 mm and 14 mm wrench.

Hardware Used

| | | | |
|-----------|-------------------|---|-----|
| BB | M8x55 Hex Bolt |  | x 2 |
| GG | M8 Nylon Lock Nut |  | x 2 |
| MM | Hitch Spacer |  | x 2 |
| NN | Ø3 R Pin |  | x 1 |
| SS | Hitch Pin |  | x 1 |

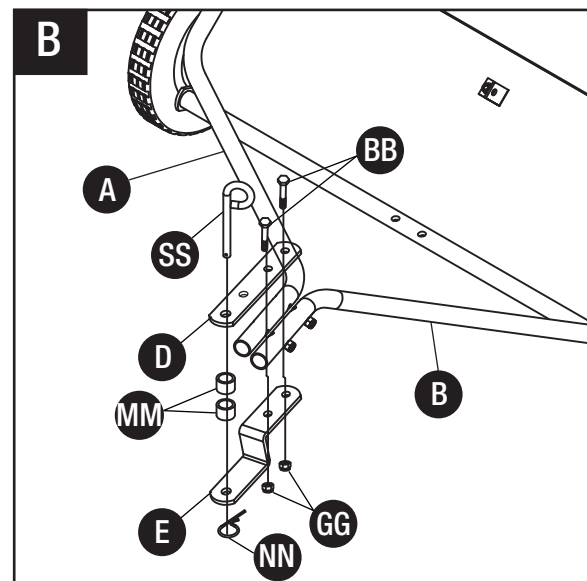
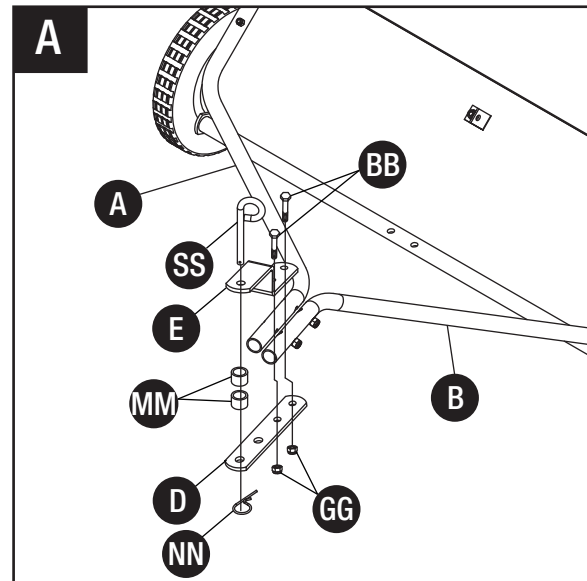

4 Mount Hitch Assembly to Hitch Tubes



CAUTION: Check to see how high the hitch is on your tractor or ATV before performing this step. Follow diagram A if your hitch is between 8' and 10' off the ground. Follow diagram B if your hitch is 11' or higher off the ground.

- Slide the Hitch Pin (SS) through the far slot in the straight hitch bracket (D).
- Follow by sliding two Hitch Spacers (MM) over the same Hitch Pin (SS).
- Slide the side of the angle bracket with one hole over the same Hitch Pin (SS).
- Secure these components on the Hitch Pin (SS) with the Ø3 R Pin (NN).
- Place the assembled hitch brackets over the end of the hitch tubes (A/B) in the orientation needed for your hitch height.

ASSEMBLY INSTRUCTIONS

5 Tighten all nuts and bolts from Steps 2 through 4.

6 Attach Height Adjustment Handle

- Place the height adjustment handle assembly (C) over the two holes on the height adjustment bar.
- Make sure the handle assembly is oriented on the right side of the machine.
- Pass two M8x40 Hex Bolts (CC) through the bottom of the height adjustment bar and the two holes on the base of the handle assembly.
- Fasten these bolts with two M8 Nylon Lock Nuts (GG) using 13 mm and 14 mm wrench..

Hardware Used

| | | | |
|-----------|-------------------|---|-----|
| CC | M8x40 Hex Bolt |  | x 2 |
| GG | M8 Nylon Lock Nut |  | x 2 |

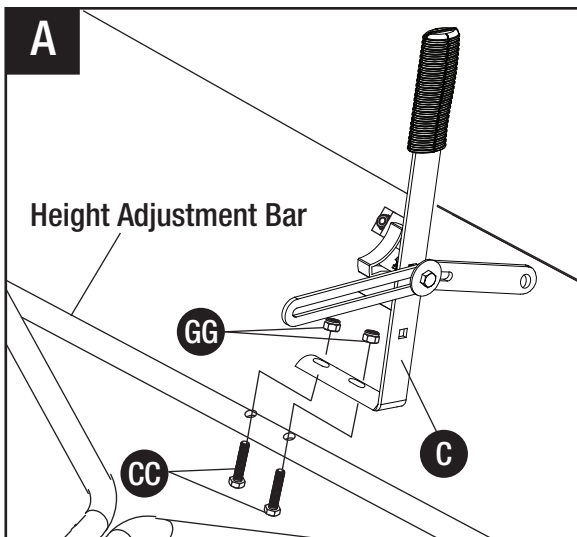

- Align the hole at the end of the handle slide arm on the right side of the Angle Bracket (KK) earlier attached to the main housing.
- Place a Spacer Bushing (LL) between the Angle Bracket (KK) and the end of the handle slide arm.
- Slide a M8x20 Hex Bolt (EE) through the Angle Bracket (KK), Spacer Bushing (LL) and handle slide arm.
- Place a Washer (JJ) over the end of this bolt and fasten with a M8 Nylon Lock Nut (GG) using 13 mm and 14 mm wrench.
- Ensure everything is aligned correctly and test the movement on the height adjustment handle.

Hardware Used

| | | | |
|-----------|-------------------|---|-----|
| EE | M8x20 Hex Bolt |  | x 1 |
| GG | M8 Nylon Lock Nut |  | x 1 |

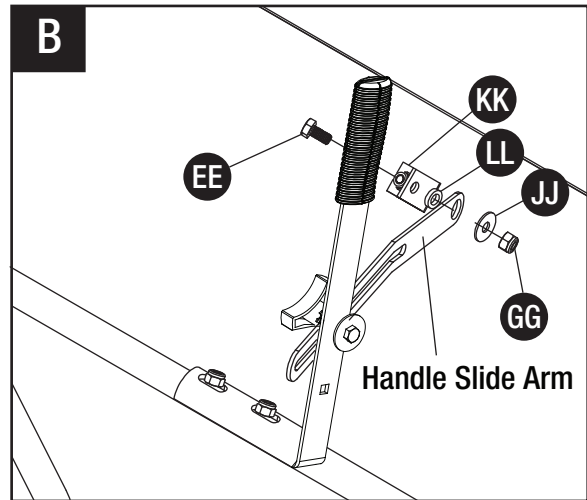

| | | | |
|-----------|----------------------|---|-----|
| JJ | Ø8 Large Flat Washer |  | x 1 |
| LL | Spacer Bushing |  | x 1 |



7 Mount the Connecting Rod to the Sweeper Housing

- Remove the right angle connecting rod (G) from the box.
- Align it on the back of the unit with a flat end pressed against the unit and a flat end on top extending in your direction.
- Slide a M6x12 Hex Bolt (II) through the hole in the connecting rod and into the top hole in the back of the main housing (H).
- Loosely fasten with a M6 Nylon Lock Nut (HH) using two 10mm wrenches.
- Repeat on the other side of the unit and tighten the nuts.

Hardware Used

| | | | |
|-----------|-------------------|---|-----|
| II | M6x12 Hex Bolt |  | x 2 |
| HH | M6 Nylon Lock Nut |  | x 2 |

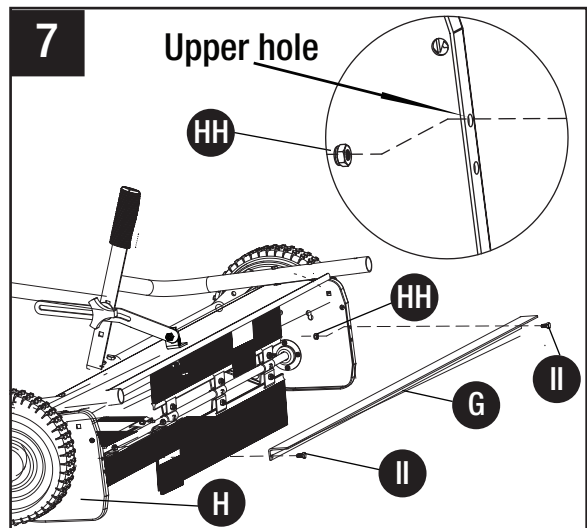

ASSEMBLY INSTRUCTIONS

8 Assemble Hopper Bag

- Unroll the hopper bag on the ground with the nylon fabric facing up and the heavy-duty nylon floor facing down.
- Remove one of the gold double ended rear hopper tubes (M) from the box.
- Place the rear hopper tube (M) in the back of the hopper fabric with the holes in the center of the bar facing up.

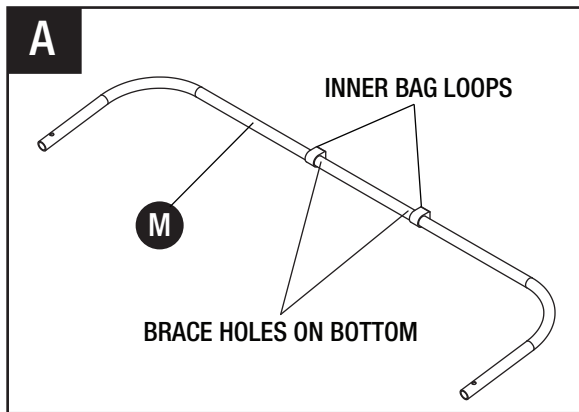

- Remove the gold lower hopper side tubes (L) from the box. These will be the two L shaped bars with two holes near one end.
- Place the male end of each tube into the female end of the lower hopper side tube (M) previously placed in the hopper.
- Make sure the smaller half of the L shape is facing upwards as shown in the diagram.
- Align the holes on both tube joins and secure by pressing in a Plastic Plug (TT) into the openings on either side.

Hardware Used

TT Plastic Plug  x 2

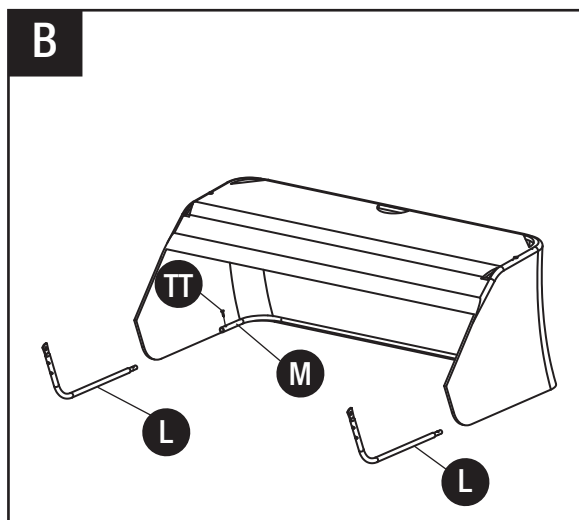

- Remove the second gold double ended rear hopper tube (M) and the two support rods (K) from the box.
- Place the two support rods (K) in the two holes in the center of the rear hopper tube (M) already seated in the hopper.
- Next take the other rear hopper tube (M) and position it to match the lower hopper side tube.
- Make sure the holes in the center of the bar are facing down.
- Step into the bag with the bar. Slide the bar into the top part of the fabric hopper and insert the two support rods (K) into the holes of the upper rear hopper tube (M).

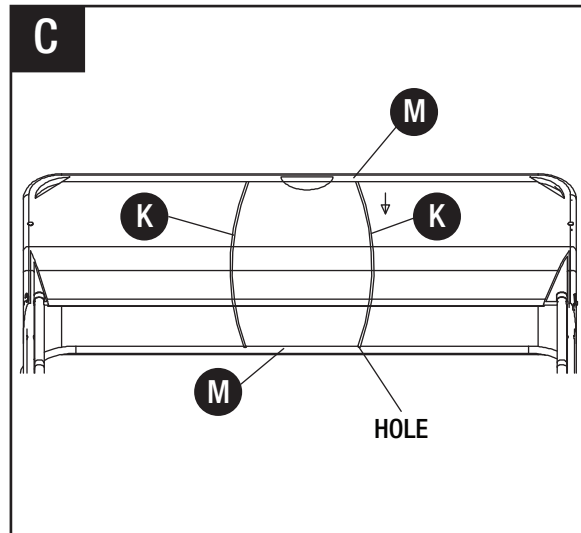

CAUTION: Do not over-stress (bend) the support rods while installing. Over stressing causes the rods to bend and lose supporting tension.

- Remove the remaining gold upper hopper side tubes (N) from the box.
- Slide these through the fabric sleeves on each side with the smaller end of the L shape facing the rear of the bag.
- Place the male end of each tube into the female end of the upper rear hopper tube (M) previously placed in the hopper.
- Make sure the Larger half of the L shape is facing downwards as shown in the diagram.
- Align the holes on both tube joins and secure by pressing in a Plastic Plug (TT) into the openings on either side.

Hardware Used

TT Plastic Plug  x 2

ASSEMBLY INSTRUCTIONS

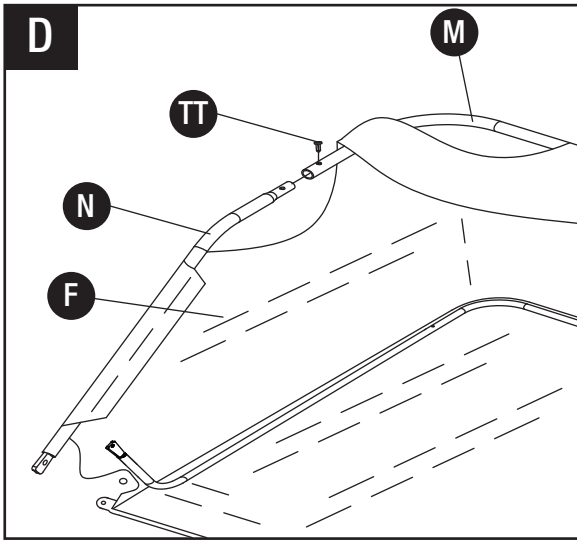

- Then align the two ends of the upper and lower hopper side tubes and insert $\text{Ø}9.5 \times 25$ Clevis Pin (PP).
- Secure the $\text{Ø}9.5 \times 25$ Clevis Pin (PP) on the other end with an $\text{Ø}3$ R Pin (NN).
- Repeat on the other side.

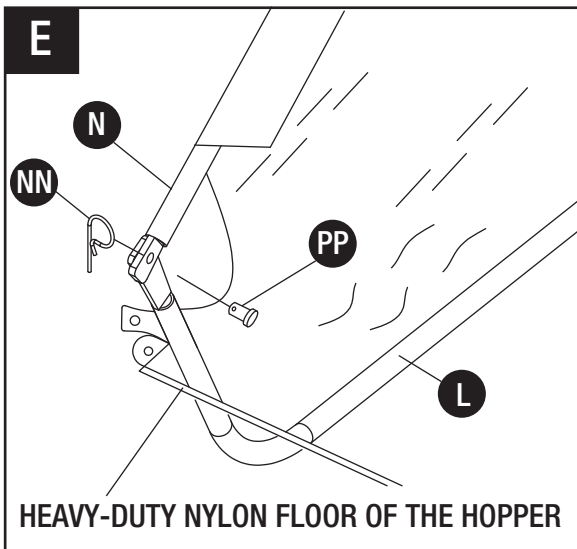

Hardware Used

| | | | |
|-----------|------------------------------------|---|-----|
| NN | $\text{Ø}3$ R Pin |  | x 2 |
| PP | $\text{Ø}9.5 \times 25$ Clevis Pin |  | x 2 |



- Remove the bag frame strap (J) from the box.
- Locate the stitched fabric sleeve at the base of the hopper in at the front of the canvas.
- Insert the bag frame strap (J) into the sleeve.
- Pull the base of the hopper fabric up towards the joint of the upper and lower hopper side tubes and insert $\text{Ø}6 \times 37$ Clevis Pin (QQ).
- Secure the $\text{Ø}6 \times 37$ Clevis Pin (QQ) on the other end with an $\text{Ø}2$ R Pin (OO).
- Repeat on the other side.

Hardware Used

| | | | |
|-----------|----------------------------------|---|-----|
| OO | $\text{Ø}2$ R Pin |  | x 2 |
| QQ | $\text{Ø}6 \times 37$ Clevis Pin |  | x 2 |

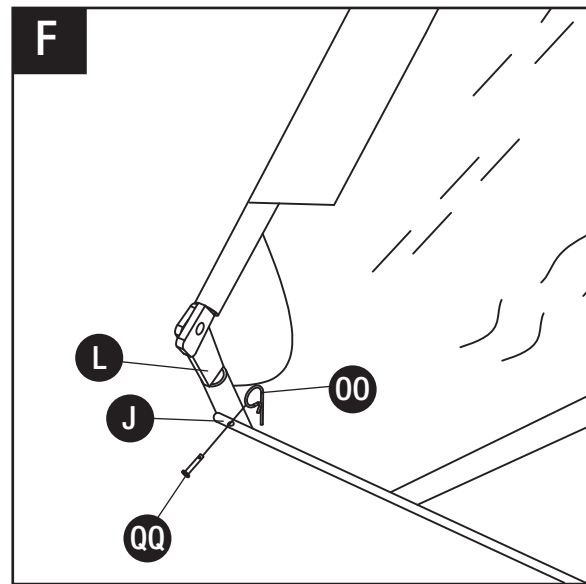

- Locate the snap buttons on the nylon fabric. Snap them into the rivets on the heavy-duty nylon floor of the hopper.

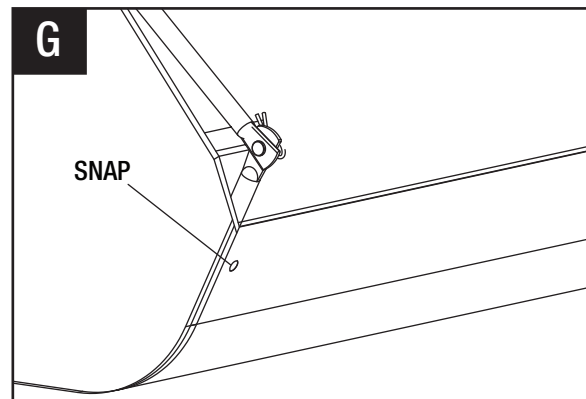

ASSEMBLY INSTRUCTIONS

9 Attach Hopper Bag to Sweeper

- There are two holes in the bar of each of the upper hopper side tubes (N). Locate the top hole and pierce the nylon fabric at the location of the top hole. **Note: some models have rivets in the fabric and do not require piercing the fabric.**
- Insert the front support rod (P) through the top hole in each of the upper hopper side tubes and assemble bag arm tube (I). Secure with Ø3 R pin (NN).
Note the orientation of the bag arm tube: vinyl cap upward, male end facing down and the arm tube (I) on the inside of the hopper bag (F).

Hardware Used

NN Ø3 R Pin  x 2

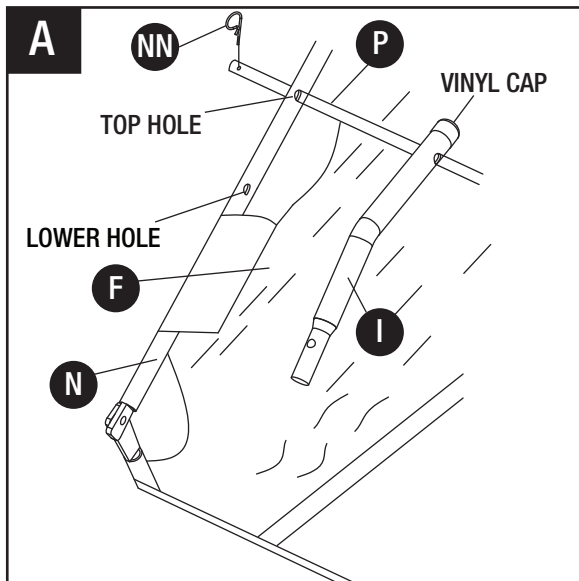

- Insert the male ends of the bag arm tubes (I) into the hitch tubes at the back of the sweeper housing assembly (away from the hitch). Secure using Ø6x42 clevis pins (RR) and Ø2 R pin (OO).

Hardware Used

OO Ø2 R Pin  x 2

RR Ø6x42 Clevis Pin  x 2

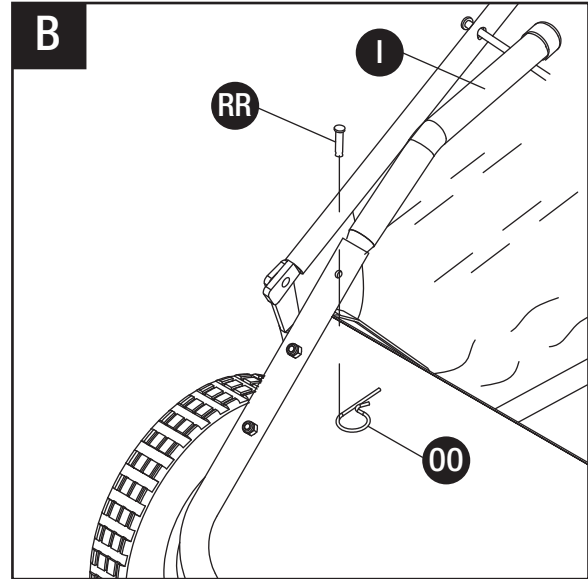

- Tie the rope to the upper hopper tube at the center of the bag frame.

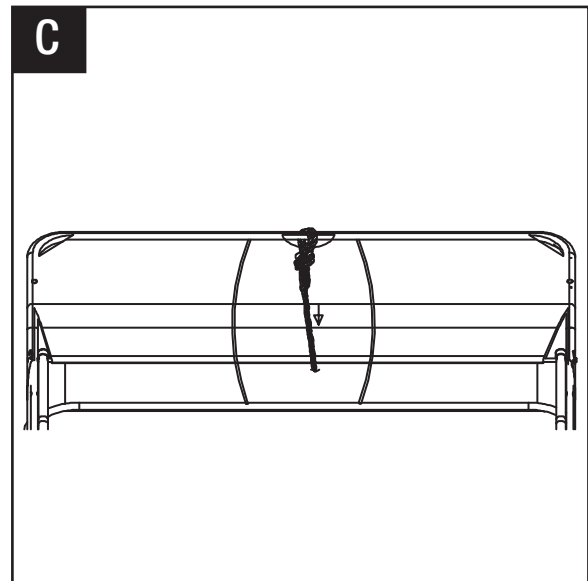

- Check to see that brush protection boards are removed from inside of sweeper housing assembly.
- Check to see that all bolts are tightened adequately and all pins are mounted securely. If all the components are securely in place, the sweeper is completely assembled and ready for use.

OPERATING INSTRUCTIONS



WARNING: Before operating or using the sweeper, review the instructions below and safety information. Failure to follow these instructions may result in property damage or injury to the operator or bystanders.

Attach the Sweeper to the Towing Vehicle

On a level surface, line up the towing vehicle with sweeper. As shown in the diagram, use the hitch pin and spacers to adjust the height of the tow hitch. Once adjusted, insert the Ø3 R Pin to secure the hitch pin. For best results, the hopper should be level with the ground at a minimum clearance of 5". Secure the rope to the tow vehicle.

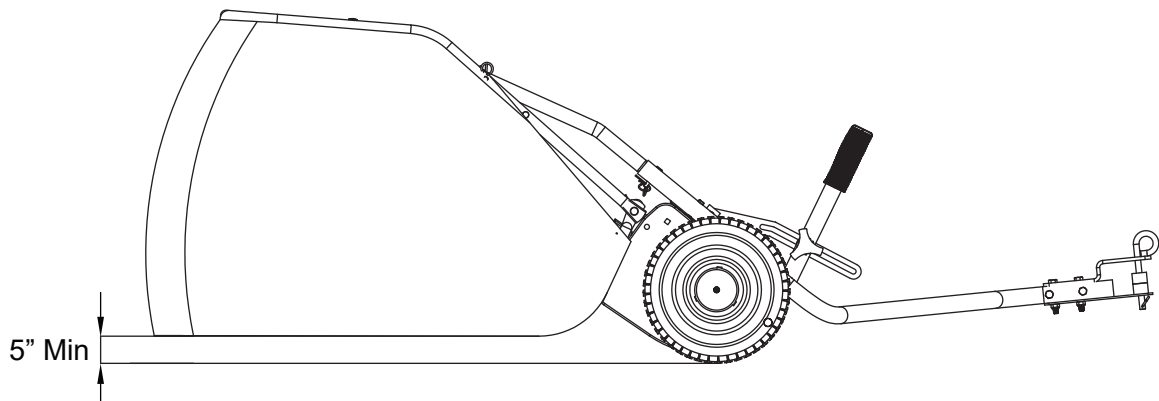
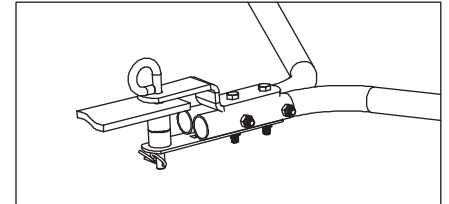
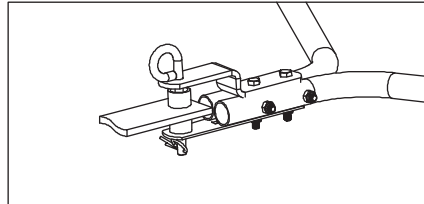
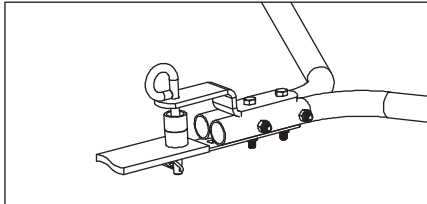

Adjust the Height of the Brushes

Use the height adjustment handle to set the height of the brushes. For optimal results, the brush height should be ½" below the tips of the grass. For sweeping other materials, you may need to adjust the height of the brushes.

Towing the Sweeper

Your sweeper is designed to work at speeds of 5 mph and lower. You may damage the device or experience sub-optimal results if exceeding 5 mph. Your sweeper will work best on flat, smooth surfaces. If operating on a slope, always tow the sweeper up or down the surface of the hill, not sideways along the slope.

Dumping the Hopper

When dumping the hopper, use the rope to pull the basket forward. Dump the hopper regularly for best performance.



CAUTION: Always keep body parts clear from and clothing detached from the sweeper and rope. Keep sweeper away from fire and excessive heat that will cause damage to the brushes and bag.

MAINTENANCE



WARNING: Improper maintenance and storage of the sweeper may void your warranty.

MAINTENANCE

- After each use clean material out of hopper.
- Rinse/dry inside and outside of the sweeper after each use.
- Periodically check all fasteners for tightness and replace any damaged fasteners.
- Check brushes for debris and keep brushes and brush shaft clean for optimal performance.
- Twice a year apply a few drops of light multipurpose oil to the brush shaft bearings.
- Annually clean and lightly lubricate all moving parts.
- Every two years remove and clean gears and apply an even coat of light synthetic grease.
- Use a glossy enamel spray paint to touch up scratched or worn painted metal surfaces.
- Never exceed the hopper load capacity rating, it will damage the bag.
- Regularly grease axle and wheel bearing area (and apply when needed).

LUBRICATION

The bearings in the sweeper have been pre-lubricated at the factory; however, it is recommended that a few drops of light multipurpose oil should be added to the brush shaft bearings twice a year. Also, every two years the wheels should be removed to clean the gears. After cleaning the gears, apply an even coat of light synthetic grease.

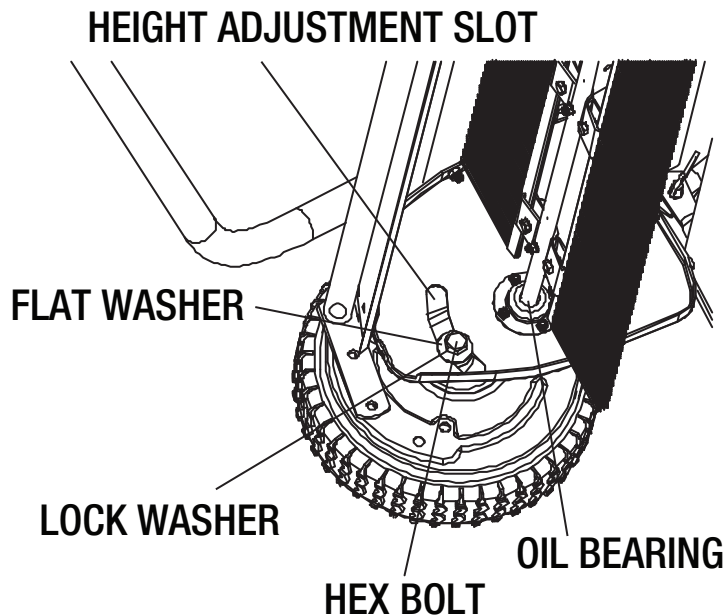

CAUTION: To remove wheel, use a screwdriver to pop off hub cap, remove the lock nut and washer.

MAINTENANCE

WHEEL GEARS/PAWL SERVICE

DO NOT remove both wheels at the same time. Remove one wheel at a time to prevent mixing parts or using the wrong parts as the left and right wheels and parts are different. When removing gears, carefully note the position of all washers and other parts.

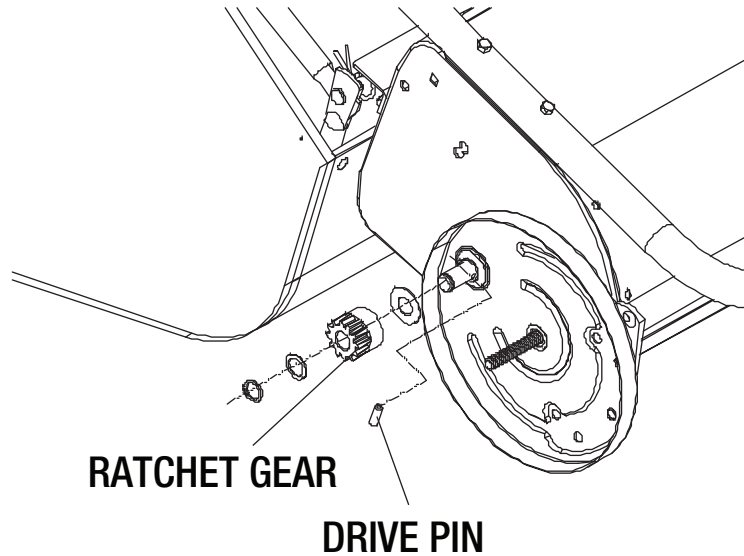

BRUSH REPLACEMENT

- Remove the hopper bag from lawn sweeper.
- Only replace one brush at a time.
- Tip the sweeper forward on housing. Do not remove the hex bolts from double brush retainers.
- Loosen hex bolts and hex lock nuts from single brush retainers. Slide brush out of retainers, making note of over-lap bristles position.
- Install new brush, make sure the over-lap bristles are in the same position as before replacement.

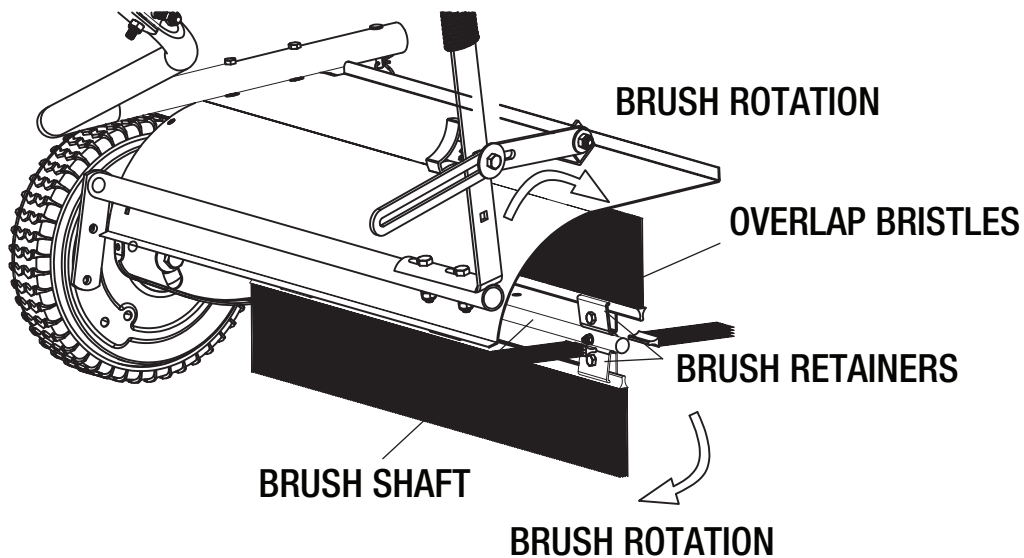

CAUTION: If a part needs replacement, only use parts that meet the manufacturer's specifications. Replacement parts that do not meet specifications may result in a safety hazard and/or poor operation.

STORAGE AND SPECIFICATIONS



Empty hopper bag before storage as full or partially full bags may pop/explode.

STORAGE

- Be sure to completely empty, clean and dry the sweeper hopper bag before storage.
- Failure to properly clean the sweeper and hopper may cause deterioration such as rust or mold.
- Lightly lubricate all sweeper surfaces and moving parts to protect components and prevent rust.
- Store indoors or in a protected area during severe weather and winter months.
- Storing the sweeper:
 - Pull the two bag arm tubes (I) out of hitch tubes (A & B).
 - Remove the two hopper support rods (K).
 - Don't allow the brushes to contact the ground during storage to prevent damage.

SPECIFICATIONS

| | |
|--------------------------|----------------|
| Frame Construction..... | Steel |
| Hopper Construction..... | Nylon Mesh |
| Hitch Type..... | Pin Style |
| Wheel Type..... | Semi-Pneumatic |
| Wheel Size..... | 10.5" |

PARTS DRAWING

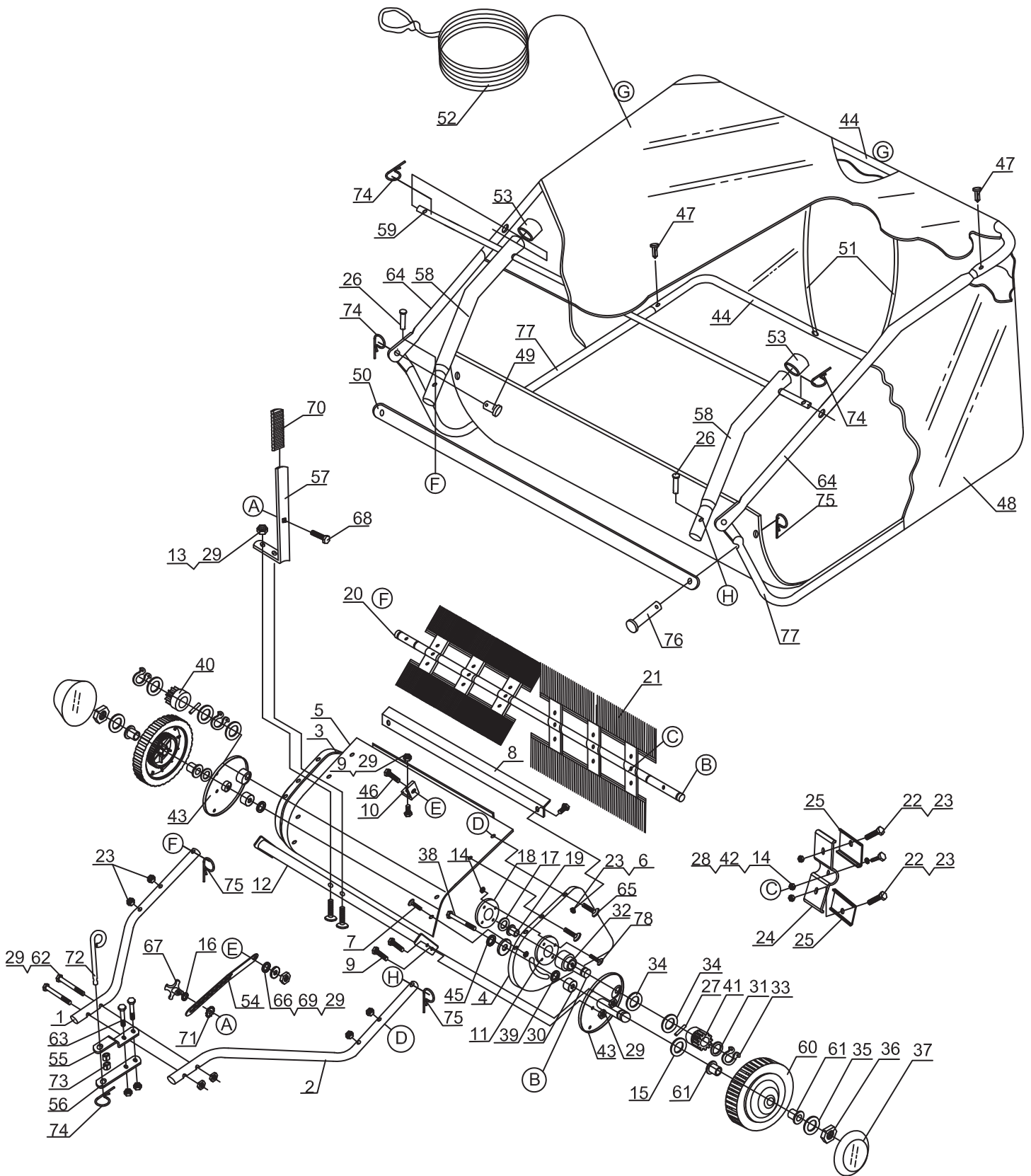

PARTS LIST

| Ref# | Drawing No. | Description | Qty |
|------|-------------------------------|-----------------------------|-----|
| 1 | N281-00023 / N287-00023 | Hitch Tube, Right Side | 1 |
| 2 | N281-00022 / N287-00022 | Hitch Tube, Left Side | 1 |
| 3 | N280-10004 | End plate, Right Side | 1 |
| 4 | N280-60001 | End plate, Left Side | 1 |
| 5 | N281-00013 / N287-00013 | Wrapper | 1 |
| 6 | 9101-06012-DXQ | Hex Bolt, M6×12 | 2 |
| 7 | 9110-05012-DX | Hex Bolt, M5×12 | 6 |
| 8 | N281-00003-CD / N287-00003-CD | Connecting Rod | 1 |
| 9 | 9101-08016-DXQ | Hex Bolt, M8×16 | 5 |
| 10 | N280-00014-DX | Angle Bracket | 1 |
| 11 | N280-10003-DX | Special Washer | 1 |
| 12 | N281-40000 / N287-40000 | Height Adjustment Tube Assy | 1 |
| 13 | 9101-08040-DXQ | Hex Bolt, M8×40 | 2 |
| 14 | 9206-05000-DX | Nylon Lock Nut, M5 | 20 |
| 15 | N280-00043-FH | Adj. Washer C | 2 |
| 16 | N280-00046-DX | Big Flat Washer | 1 |
| 17 | N280-00033-DX | Inside Star Washer | 1 |
| 18 | N280-10001-DX | Dust Cover Retainer | 1 |
| 19 | N280-10002 | Brush Shaft Bushing | 1 |
| 20 | N281-00027-DX / N287-00027-DX | Brush Shaft | 1 |
| 21 | N281-31000 / N287-31000 | Brush | 4 |
| 22 | 9101-06020-DXQ | Hex Bolt, M6×20 | 16 |
| 23 | 9206-06000-DX | Nylon Lock Nut, M6 | 30 |
| 24 | N280-30001-DX | Retainer, Brush (Double) | 6 |
| 25 | N280-30002-DX | Retainer, Brush (Single) | 12 |
| 26 | N281-00010-DX | Clevis Pin E | 2 |
| 27 | 9401-06020 | Dowel Pin (Drive) | 2 |
| 28 | 9316-05000-FH | Mounting Lock Washer, Ø5 | 6 |
| 29 | 9206-08000-DX | Nylon Lock Nut, M8 | 12 |
| 30 | N280-00035-DX | Spacer for Axle | 2 |
| 31 | N280-00037-FH | Adj. Washer B | 2 |
| 32 | N280-00028-DX | Bushing | 2 |
| 33 | 9309-15000-FH | Retaining Ring, Ø15 | 2 |
| 34 | N280-00029-FH | Adj. Washer A | 4 |
| 35 | 9302-10000-DX | Big Flat Washer, Ø10 | 4 |
| 36 | 9206-10000-DX | Nylon Lock Nut, M10 | 2 |
| 37 | N280-00032 | Hub Cap | 2 |
| 38 | 9101-10085-DX | Hex Bolt, M10×85 | 2 |
| 39 | N280-00036-DX | Spacer Bushing Ø16×3.5 | 2 |

PARTS LIST

| Ref# | Drawing No. | Description | Qty |
|------|----------------------------|-----------------------------------|-----|
| 40 | N280-00012 | Pinion Gear R.H. | 1 |
| 41 | N280-00030 | Pinion Gear L.H. | 1 |
| 42 | 9101-05025-DXQ | Hex Bolt M5x25 | 6 |
| 43 | N280-50000 | Dust Cover Assy | 2 |
| 44 | N281-00006-CD / N287-00006 | Hopper Frame Tube (Rear) | 2 |
| 45 | 9306-1000-DX | Lock Washer Ø10 | 2 |
| 46 | 9101-08020-DXQ | Hex Bolt M8x20 | 1 |
| 47 | N280-00002 | Plastic Plug | 4 |
| 48 | N281-00039 / N287-00039 | Hopper Bag | 1 |
| 49 | N280-00016-DX | Clevis Pin C | 2 |
| 50 | N281-00015 / N287-00015 | Bag Frame Strap | 1 |
| 51 | N282-00009 | Hopper Support Rod | 2 |
| 52 | N280-00038 | Hopper Rope | 1 |
| 53 | N281-00009 | Vinyl Cap | 2 |
| 54 | N280-00019-DX | Handle Slide Arm | 1 |
| 55 | N100-00014 | Hitch Bracket | 1 |
| 56 | N280-00025 | Hitch Bracket(Straight) | 1 |
| 57 | N280-00020 | Height Adjustment Handle | 1 |
| 58 | N281-00011 | Bag Arm Tube | 2 |
| 59 | N281-00028-DX / N287-00028 | Front Support Rod | 1 |
| 60 | N281-20000 | Wheel & Tire Assy. (with bearing) | 2 |
| 61 | N280-00034 | Wheel Bushing | 4 |
| 62 | 9101-08075-DX | Hex Bolt,M8×75 | 2 |
| 63 | 9101-08055-DX | Hex Bolt,M8×55 | 2 |
| 64 | N281-00008-CD / N281-00008 | Upper Hopper Frame Tube | 2 |
| 65 | 9101-06045-DXQ | Hex Bolt,M6x45 | 4 |
| 66 | N280-00048-DX | Spacer Bushing Adjusting Height | 1 |
| 67 | N280-70000 | Knob, Plastic | 1 |
| 68 | 9114-08030-DX | Carriage Bolt,M8×30 | 1 |
| 69 | 9302-08000-DX | Big Flat Washer,Ø8 | 1 |
| 70 | N280-00004 | Handle Grip | 1 |
| 71 | N280-00044-DX | External Teeth Washer | 1 |
| 72 | N021-00003-DX | Hitch Pin | 1 |
| 73 | N280-00026-DX | Snap-Ring Bearing | 2 |
| 74 | N280-00047-DX | R Pin Ø3 | 5 |
| 75 | N280-00041-DX | R Pin Ø2 | 4 |
| 76 | N280-00010-DX | Clevis Pin B | 2 |
| 77 | N280-00006-CD / N280-00006 | Lower Hopper Frame Tube | 2 |
| 78 | 9110-05016-DX | Screw M5x16 | 8 |